

**SAMSUNG**

# GSM TELEPHONE

## SGH-M600S

# ***SERVICE*** *Manual*

### GSM TELEPHONE



### CONTENTS

1. Specification
2. Exploded View and Parts List
3. Flow Chart of Troubleshooting
4. Array course control
5. Block Diagrams
6. PCB Diagrams
7. MAIN Electrical Parts List
8. Reference data
9. Safety Precautions
10. Product Function

**SAMSUNG  
ELECTRONICS**



GSPN (Global Service Partner Network)

<b>Country</b>	<b>Web Site</b>
North America	<a href="http://service.samsungportal.com">service.samsungportal.com</a>
Latin America	<a href="http://latin.samsungportal.com">latin.samsungportal.com</a>
CIS	<a href="http://cis.samsungportal.com">cis.samsungportal.com</a>
Europe	<a href="http://europe.samsungportal.com">europe.samsungportal.com</a>
China	<a href="http://china.samsungportal.com">china.samsungportal.com</a>
Asia	<a href="http://asia.samsungportal.com">asia.samsungportal.com</a>
Mideast & Africa	<a href="http://mea.samsungportal.com">mea.samsungportal.com</a>

# Contents

## 1. Specification

1-1. GSM General Specification .....	1-1
1-2. GSM Tx Power Class .....	1-2

## 2. Exploded View and Parts List

2-1. Cellular phone Exploded View .....	2-1
2-2. Cellular phone Part list .....	2-2
2-3. Disassembly .....	2-4
2-4. Assembly .....	2-6
2-5. LCD KIT .....	2-8

## 3. Flow Chart of Troubleshooting

3-1. Baseband	
3-1-1. Power ON .....	9-1
3-1-2. Initial .....	9-4
3-1-3. Sim Part .....	9-6
3-1-4. Charging Part .....	9-8
3-1-5. Microphone Part .....	9-9
3-1-6. Speaker Part .....	9-11
3-1-7. LCD .....	9-13
3-1-8. Camera .....	9-16
3-2. RF	
3-2-1. GSM Receiver.....	3-18
3-2-2. DCS Receiver.....	3-19
3-2-3. PCS Receiver.....	3-20
3-2-4. GSM Transmitter.....	3-23
3-2-5. DCS Transmitter.....	3-24
3-2-6. PCS Transmitter.....	3-25
3-2-7. Bluetooth Part .....	3-27

## 4. Array course control

Software Downloading	
4-1. Downloading Binary Files .....	4-2
4-2. Pre-requisite for Downloading .....	4-2
4-3. S/W Downloader Program .....	4-3

---

# Contents

## 5. MAIN Electrical Parts List

## 6. Block Diagrams

## 7. PCB Diagrams

## 8. Reference data

## 9. Safety Precautions

9-1. Repair Precaution .....9-1

9-2. ESD(Electrostatically Sensitive Devices) Precaution .....9-2

## 10. Product Function

10-1. Main Function .....10-1

---

# 1. Specification

---

## 1-1. GSM General Specification

	<b>GSM 900 Phase 1</b>	<b>EGSM 900 Phase 2</b>	<b>DCS1800 Phase 1</b>
Freq. Band[MHz] Uplink/Downlink	890~915 935~960	880~915 925~960	1710~1785 1805~1880
ARFCN range	1~124	0~124 & 975~1023	512~885
Tx/Rx spacing	45 MHz	45 MHz	95 MHz
Mod. Bit rate/ Bit Period	270.833 Kbps 3.692 us	270.833 Kbps 3.692 us	270.833 Kbps 3.692 us
Time Slot Period/Frame Period	576.9 us 4.615 ms	576.9 us 4.615 ms	576.9 us 4.615 ms
Modulation	0.3 GMSK	0.3 GMSK	0.3 GMSK
MS Power	33 dBm~13 dBm	33 dBm~5 dBm	30 dBm~0 dBm
Power Class	5 pcl ~ 15 pcl	5 pcl ~ 19 pcl	0 pcl ~ 15 pcl
Sensitivity	-102 dBm	-102 dBm	-100 dBm
TDMA Mux	8	8	8
Cell Radius	35 Km	35 Km	2 Km

**1-2. GSM TX power class**

<b>TX Power control level</b>	<b>GSM900</b>	<b>TX Power control level</b>	<b>DCS1800</b>
5	33±2 dBm	0	30±3 dBm
6	31±2 dBm	1	28±3 dBm
7	29±2 dBm	2	26±3 dBm
8	27±2 dBm	3	24±3 dBm
9	25±2 dBm	4	22±3 dBm
10	23±2 dBm	5	20±3 dBm
11	21±2 dBm	6	18±3 dBm
12	19±2 dBm	7	16±3 dBm
13	17±2 dBm	8	14±3 dBm
14	15±2 dBm	9	12±4 dBm
15	13±2 dBm	10	10±4 dBm
16	11±3 dBm	11	8±4 dBm
17	9±3 dBm	12	6±4 dBm
18	7±3 dBm	13	4±4 dBm
19	5±3 dBm	14	2±5 dBm
		15	0±5 dBm

## 2. Exploded View and Parts List

### 2-1. Cellular phone Exploded View

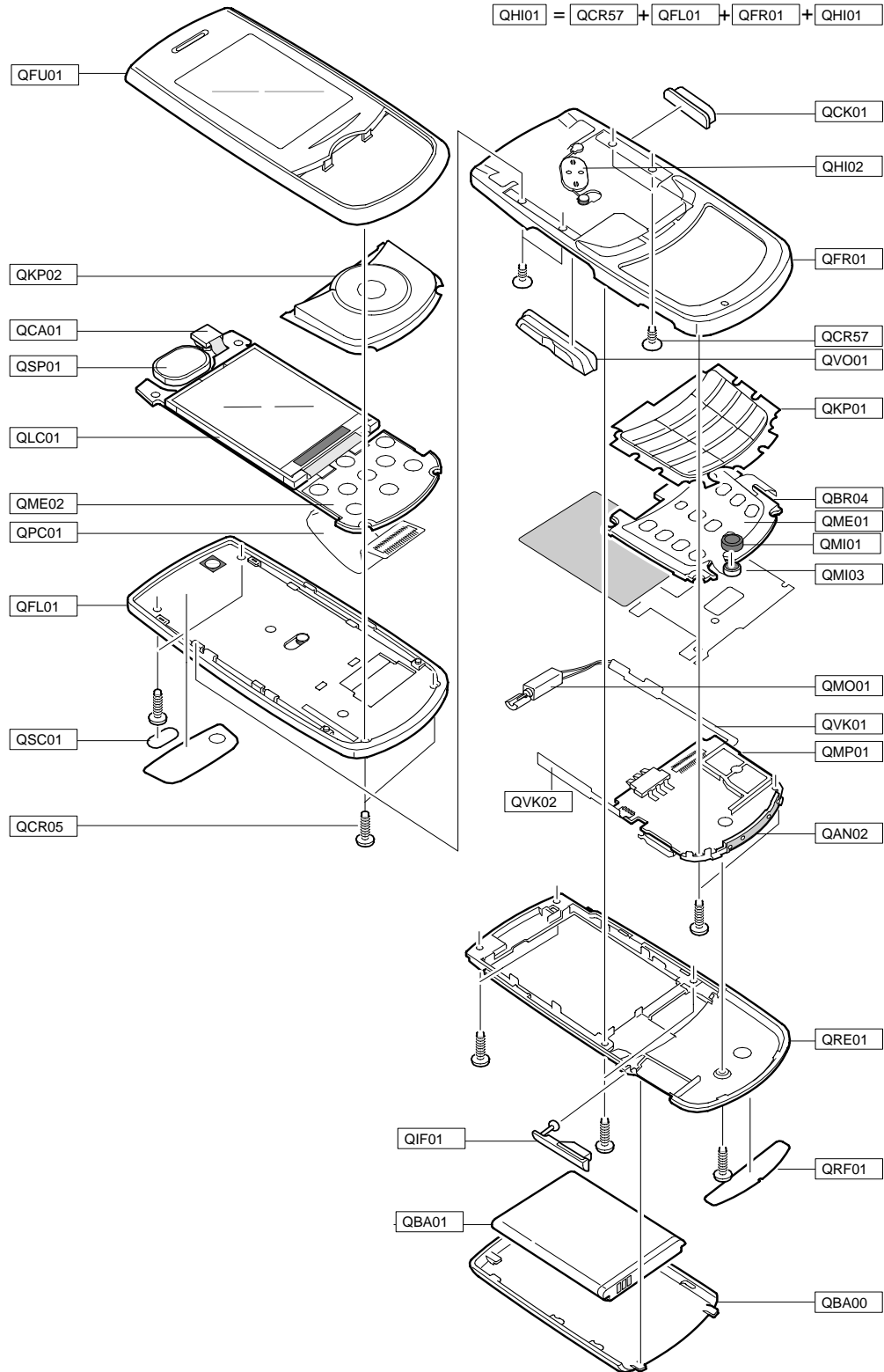



## 2-2. Cellular phone Parts list

Design LOC	Description	SEC CODE
QAN02	INTENNA-SGH_M600	GH42-01206A
QBA00	PMO-BATT COVER	GH72-39166A
QBA01	INNER BATTERY PACK-800MAH,BLK,	GH43-02719A
QBR04	ASSY KEYPAD-BRACKET	GH98-04516A
QCA01	CAMERA MODULE	GH59-04415A
QCK01	PMO-POWER KEY	GH72-39161A
QCR05	SCREW-MACHINE	6001-001478
QCR05	SCREW-MACHINE	6001-001478
QCR05	SCREW-MACHINE	6001-001478
QCR57	SCREW-MACHINE	6001-002001
QFL01	ASSY COVER-SLIDE LOWER	GH98-04440A
QFR01	ASSY COVER-FRONT	GH98-04441A
QFU01	ASSY COVER-SLIDE UPPER	GH98-04439A
QHI01	ASSY HINGE	GH98-04515A
QHI02	ASSY HINGE-SLIDE	GH98-05660A
QIF01	PMO-IF COVER	GH72-39164A
QKP01	ASSY KEYPAD-MAIN(INU/DSS)	GH98-05892A
QKP02	ASSY KEYPAD-SUB(XEF/DSA)	GH98-04443A
QLC01	ELA UNIT-SGH_M600 LCD MODULE (	GH96-02764A
QME01	KEY FPCB-KEY PBA(34KEY)	GH59-04437A
QME02	DOME SHEET-DOME SHEET 9 KEY	GH59-04438A
QMI01	AS-MIC	GH81-06707A
QMI03	AS-MIC RUBBER	GH81-06708A
QMO01	MOTOR DC-SGH-M600	GH31-00340A
QMP01	PBA MAIN-SGH_M600S	GH92-03911A
QPC01	MEA-FPCB KIT	GH97-07862A
QRE01	ASSY COVER-REAR	GH98-04442A
QRF01	ASSY COVER-RF	GH98-05002A
QSC01	PMO-SCREW CAP	GH72-39157A
QSP01	SPEAKER	3001-002165
QVK01	KEY FPCB-SIDE VOLUME	GH59-04439A
QVK02	KEY FPCB-SIDE POWER 1 KEY FPCB	GH59-04440A
QVO01	PMO-VOLUME KEY	GH72-39162A

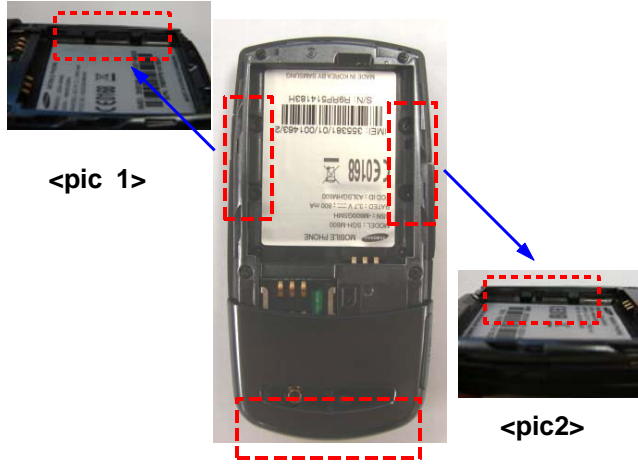

Description	SEC CODE
EARPHONE-B-TYPE	GH59-04557A
MANUAL-SFC CARD(INDA)	GH68-08768A
MANUAL USERS-INDA LEAFLET CARD	GH68-13751A
MANUAL USERS-INDA ENGLISH	GH68-15350A
BAG PE	6902-000297
LABEL(P)-UNIT SEAL	GH68-00518B
LABEL(R)-MAIN EU	GH68-15468A
BOX(P)-UNIT MAIN(INU)	GH69-05650G
VINYL-BOHO MAIN	GH74-33869A
LABEL(R)-WATER SOAK	GH68-09361A
TAPE INSU	GH74-28075A
MPR-TAPE LCD A	GH74-24670A
MPR-REMOVE TAPE LCD	GH74-13804A
MPR-INSU TAPE	GH74-28241A
TAPE-FPCB BACK	GH74-33643A
TAPE INSU	GH74-32033A
VINYL-BOHO REAR	GH74-34880A
ADAPTOR-ATADS10IBE,BLK,INDA	GH44-01765A

## 2-3. Assembly

<p><b>1</b></p> 	<p><b>2</b></p> 
<p>1) Remove RF cover using the pointed tool. 2) Disjoint the REAR Screw of 5 Points. * <b>caution</b> 1) Be careful for scratch</p>	<p>1) Disjoint REAR's lockers just like pictures below.(pic1 &amp; pic 2) 2) Disjoint other lockers too. * <b>caution</b> 1) Be careful for scratch 2) Be careful for damage of lockers.</p>
<p><b>3</b></p> 	<p><b>4</b></p> 
<p>1) Disjoint volume-key &amp; pwr-key. 2) Remove the green tape on the connector of key-pad FPCB. * <b>caution</b> 1) Be careful for crumpling &amp; crack of key-pad FPCB.</p>	<p>1) Disjoint the antenna screw of 2 points. 2) Disjoint the key-pad FPCB from connector. 3) Take off the motor from the FRONT plastic using tweezers and disjoint pwr-key FPCB &amp; volume key FPCB from the FRONT plastic. * <b>caution</b> 1) Be careful for scratch. 2) Be careful for the damage on the WIRE of Motor</p>

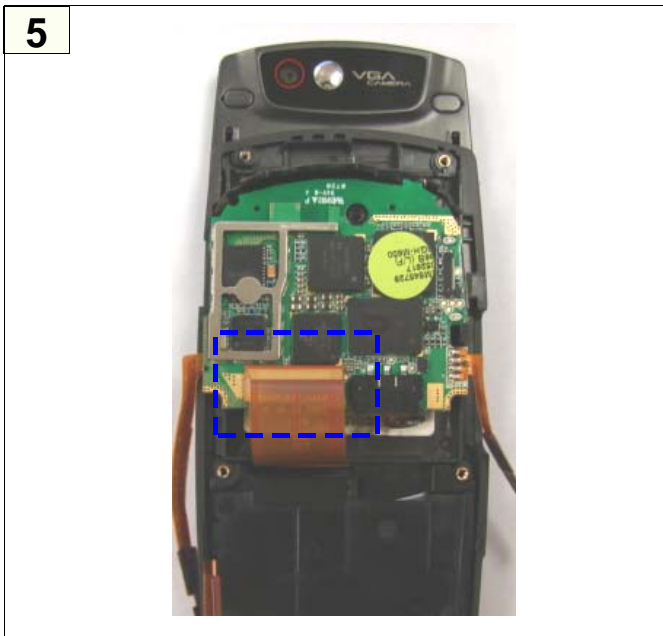

- 1) Disjoint the LCD FPCB & PBA like the picture below.
  - 2) Disjoint the PBA from the FRONT plastic.
- \* caution**
- 1) Be careful for the FPCB's crack



- 1) Disjoint the key-pad bracket from the FRONT plastic.
  - 2) Remove the Key-pad rubber.
- \* caution**
- 1) Be careful for scratch



- 1) Slide up like the picture below.
  - 2) Disjoint screw caps using tweezers.
  - 3) Disjoint LOWER plastic Screw of 4 points.
- \* caution**
- 1) Be careful for scratch.

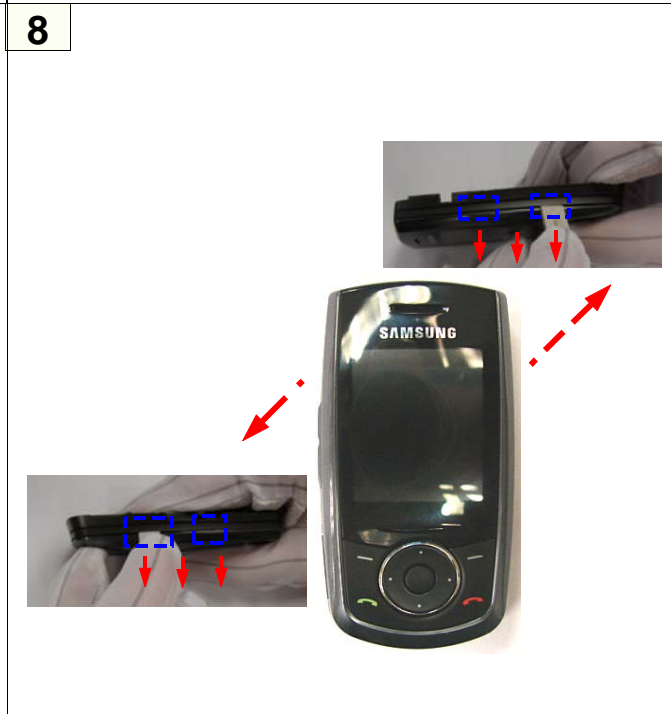



- 1) Using the Disassemble tool, Disjoint the UPPER plastic & LOWER plastic like the pictures below.
- \* caution**
- 1) Be careful for scratch.



<p><b>9</b></p> 	<p><b>10</b></p>  <p>&lt;Pic 1&gt;</p>
<p>1) Slide up like the picture below.                  2) Disjoint the Hinge ASSY from the UPPER plastic.                  * <b>caution</b>                  1) Be careful for the LCD FPCB's crack.</p>	<p>1) Lift up the LCD PBA slightly &amp; Remove the camera module,                  2) Disjoint the speaker.                  * <b>caution</b>                  1) Be careful for the damage of camera &amp; speaker</p>
<p><b>11</b></p>  <p>1) Disjoint the Navi-key from the UPPER plastic.</p>	

## 2-4. Disassembly

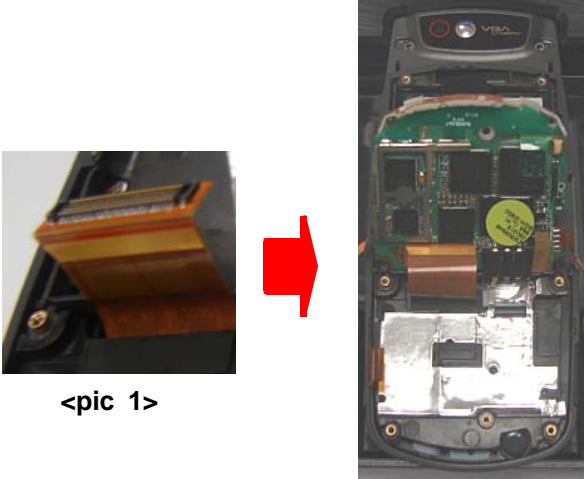
<p><b>1</b></p> 	<p><b>2</b></p> 
<p>1) Put the NAVI key like the picture below.  <b>* caution</b>          1) Put the hole of NAVY key to UPPER</p>	<p>1) Put the speaker &amp; camera.          2) Put the LCD-PBA on the UPPER plastic.  <b>* caution</b>          1) Check the fabrication status of SPK &amp; CAM          2) Be careful for the CAM FPCB's crack.</p>
<p><b>3</b></p> 	<p><b>4</b></p> 
<p>1) Slide up like the picture below.          2) Insert the FPCB through the hole at Hinge.          and Push up the LOWER plastic.          3) Push #1 &amp; #2 in numerical order.  <b>* caution</b>          1) Be careful for the scratch and crack of FPCB.          2) Be careful for the damage of LCD.</p>	<p>1) Joint the 4 screws in numerical order.  <b>* caution</b>          1) Be careful for scratch.</p>

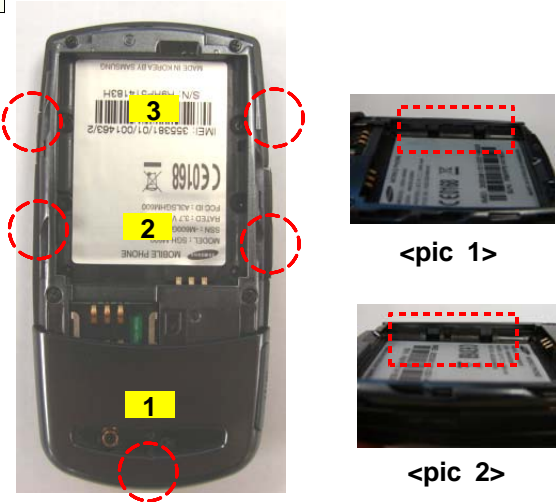

<p><b>5</b></p> 	<p><b>6</b></p>  <p>&lt;pic 1&gt;</p> <p>&lt;pic 2&gt;</p>
<p>1) Put the key-pad on the FRONT.                  2) Put the MIC and bracket like the picture                  * below                  1) Check the flatness of MIC.</p>	<p>1) Fold the FPCB like the picture below.                  2) Joint the FPCB &amp; connector.                  * <b>caution</b>                  1) Check the connection of FPCB.</p>
<p><b>7</b></p> 	<p><b>8</b></p> 
<p>1) Fold the volume key FPCB &amp; Insert the volume key into the slot.                  * <b>caution</b>                  1) Volume key must be inserted fully.</p>	<p>1) Joint the 2 intenna screws.                  * <b>caution</b>                  1) Be careful for the scratch.</p>

<p><b>9</b></p> 	<p><b>10</b></p> 
<p>1) Put the pwr-key like the picture below.                  2) Put the motor like the picture below.                  Wires must be in order like the picture below.(blue wire: top, red wire: bottom)  <b>* caution</b>                  1) Wires must be in order.</p>	<p>1) Insert the 3*4key FPCB to the CONNECTOR along the SILK LINE.                  2) Put the green TAPE on the connector.  <b>* caution</b>                  1) Check the connection of FPCB.                  2) Be careful for the scratch and crack of FPCB.</p>
<p><b>11</b></p> 	<p><b>12</b></p> 
<p>1) Insert the pwr-key.                  2) Insert the volume-key.  <b>* caution</b>                  1) Be careful for the direction of vol-key, pwr-key</p>	<p>1) Insert the 3*4key FPCB to the CONNECTOR along the SILK LINE.                  2) Put the green TAPE on the connector.  <b>* caution</b>                  1) vol-key, pwr-key FPCB must be covered with REAR COVER plastic.                  2) Be careful not to give damage to locker.</p>

13



- 1) Joint the 5 screws of REAR COVER plastic.
- 2) Joint the RF cover.

※ **caution**

- 1) Be careful for the scratch.



### 3. Flow Chart of Troubleshooting

#### 3-1. Baseband

##### 3-1-1. Power ON

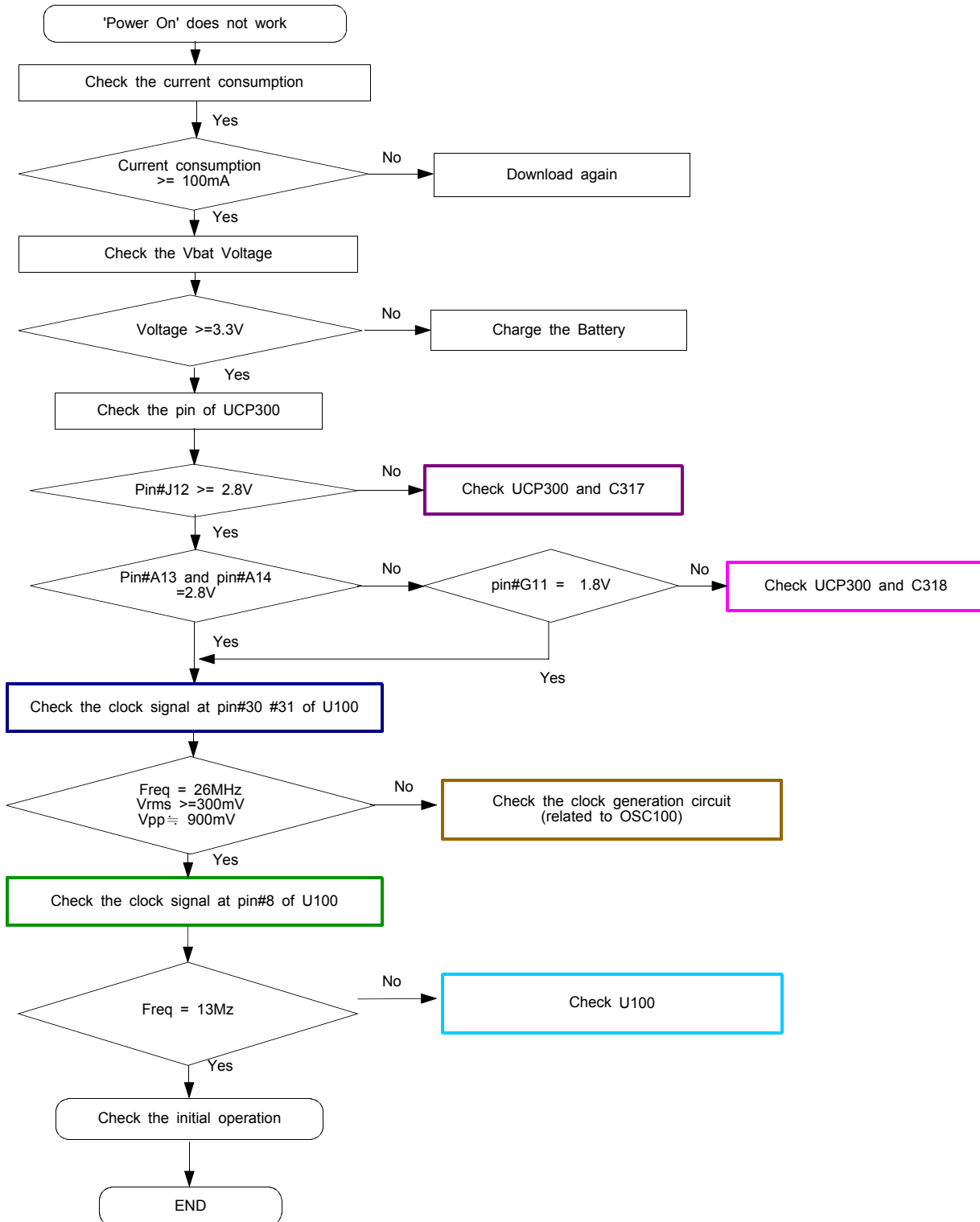

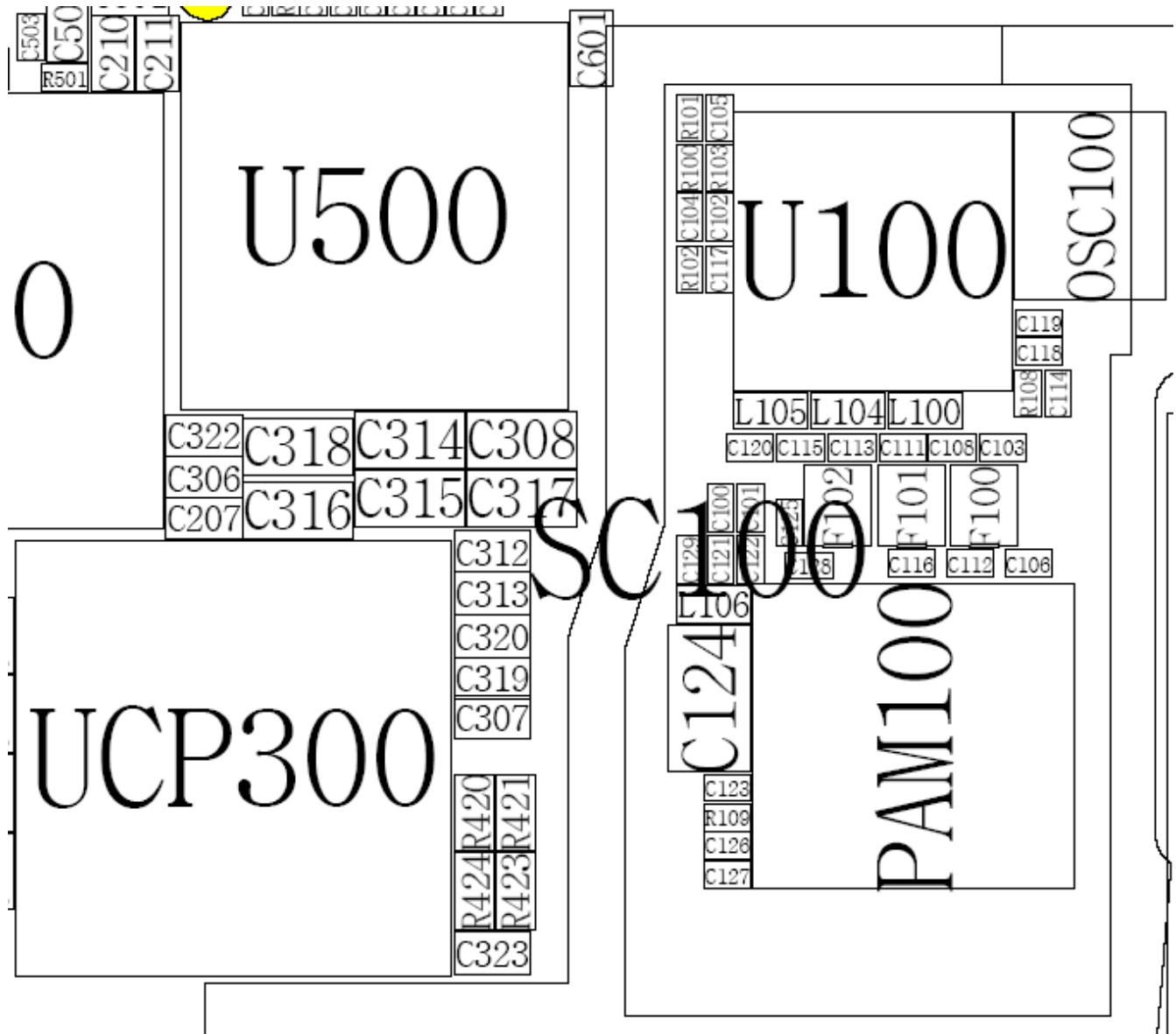

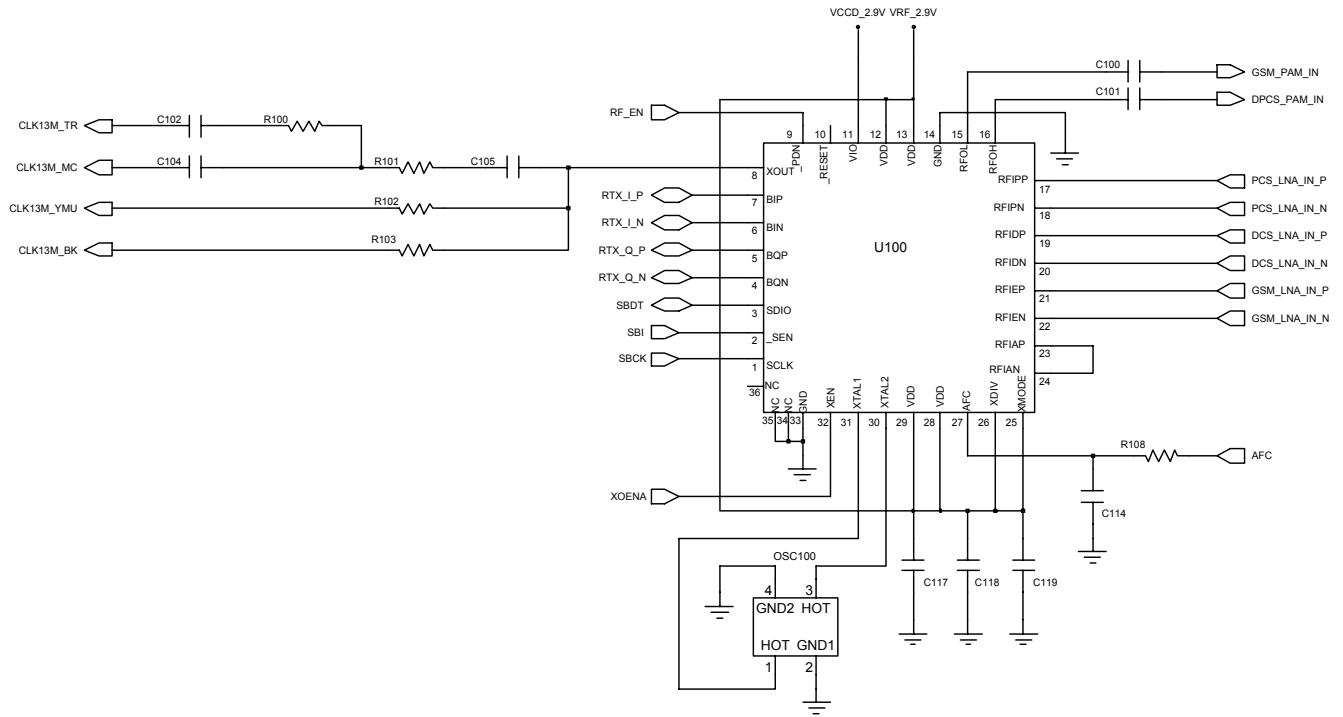

### 3-1-2. Initial

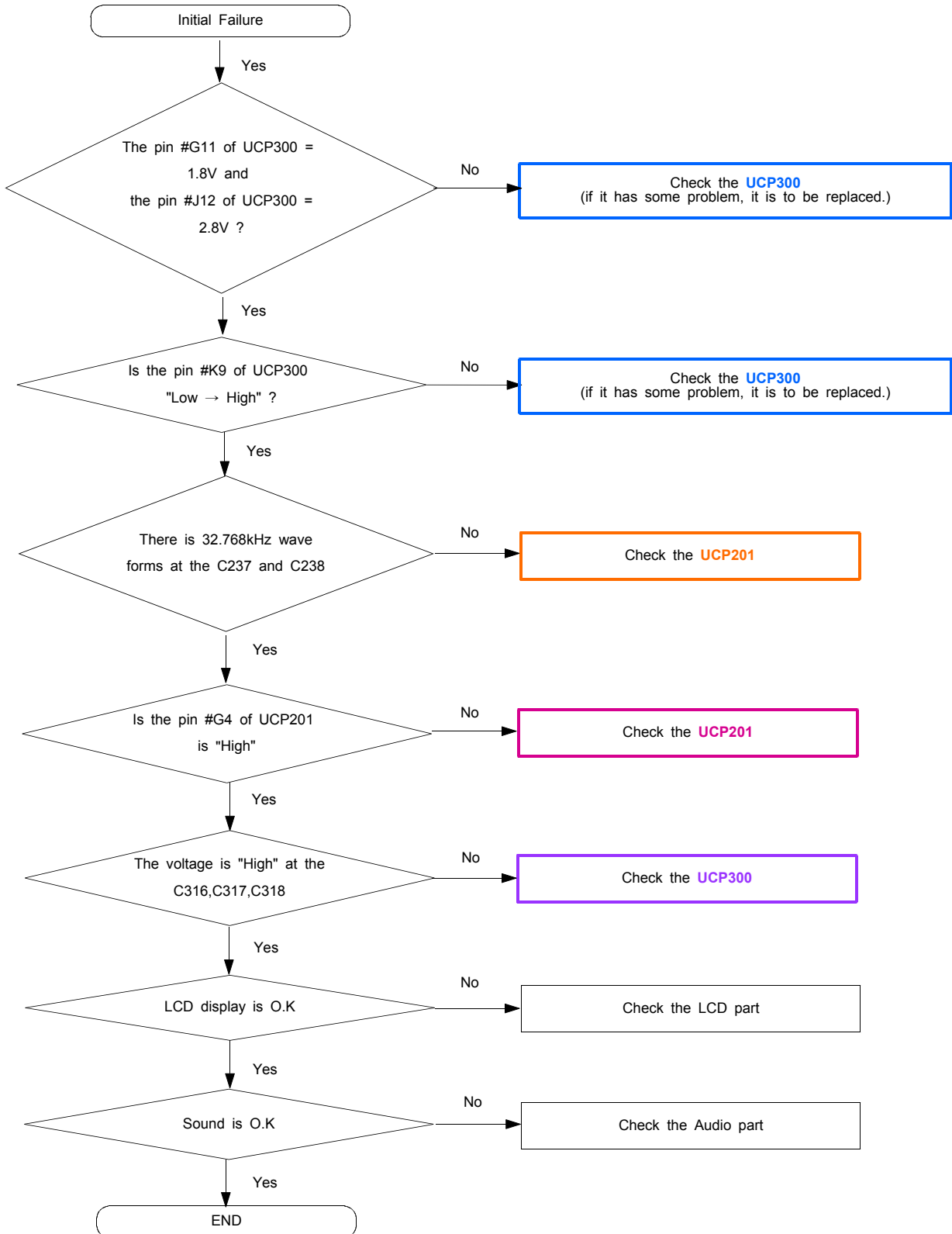

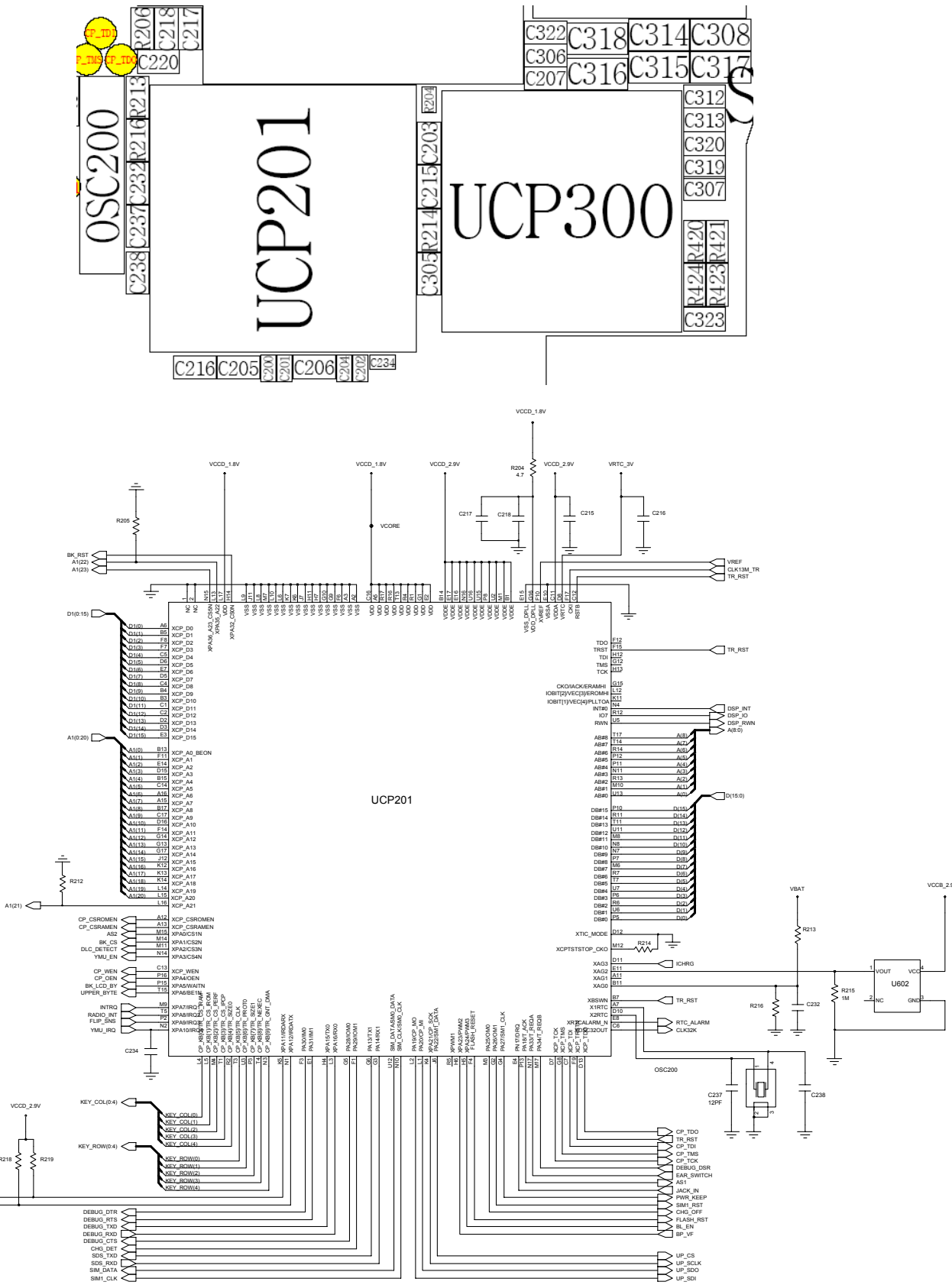

### 3-1-3. Sim Part

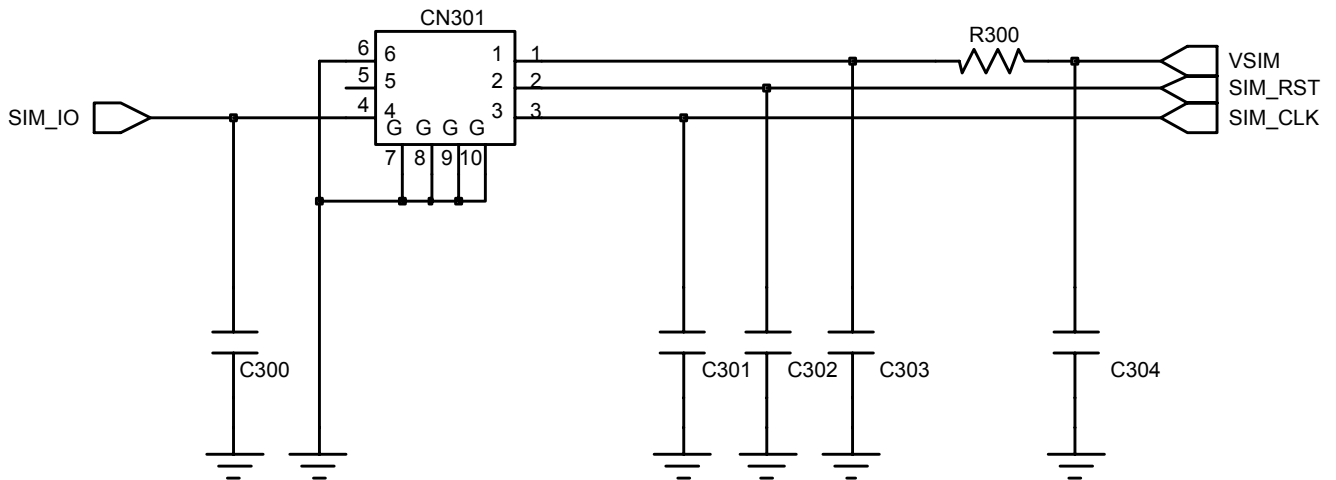
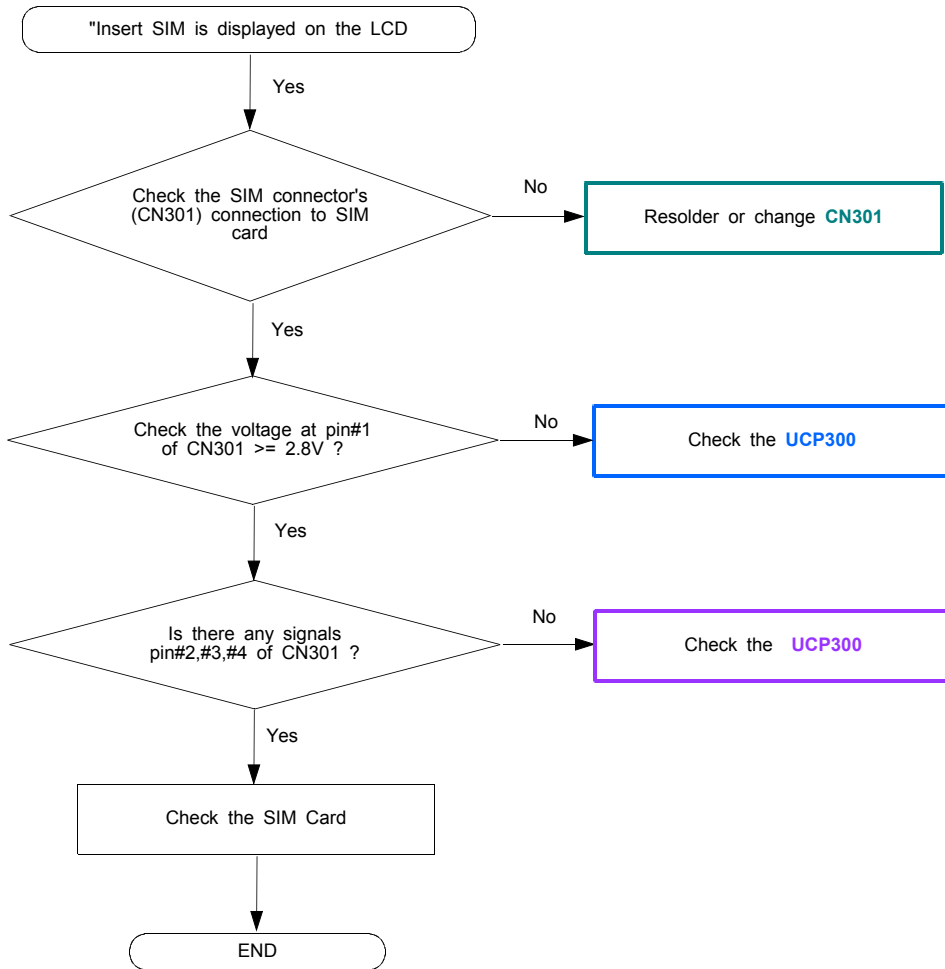

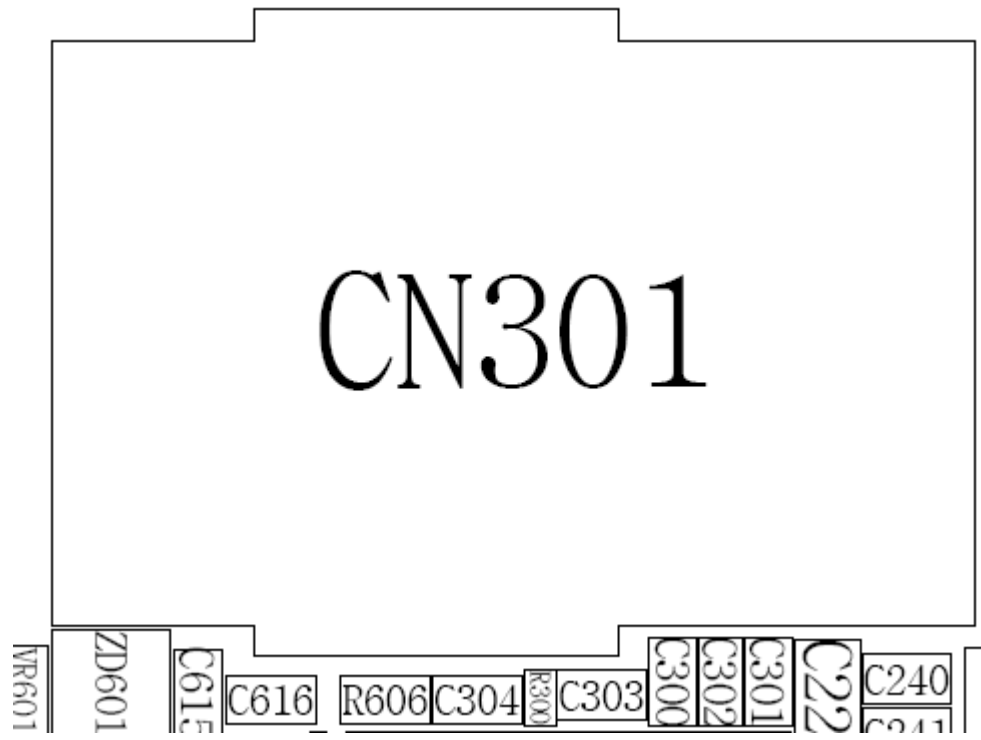

### 3-1-4. Microphone Part

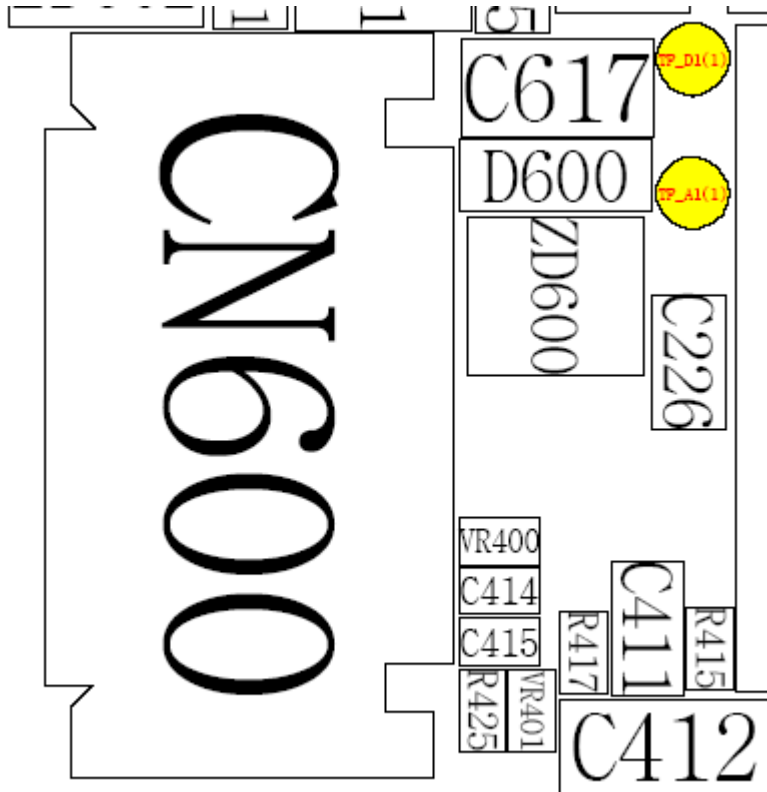
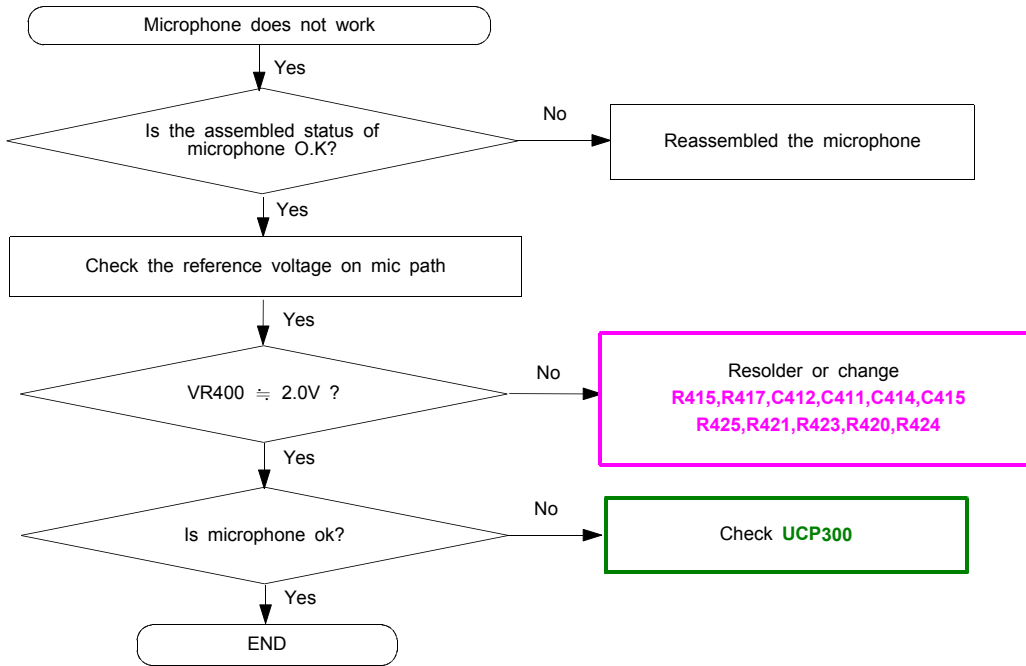



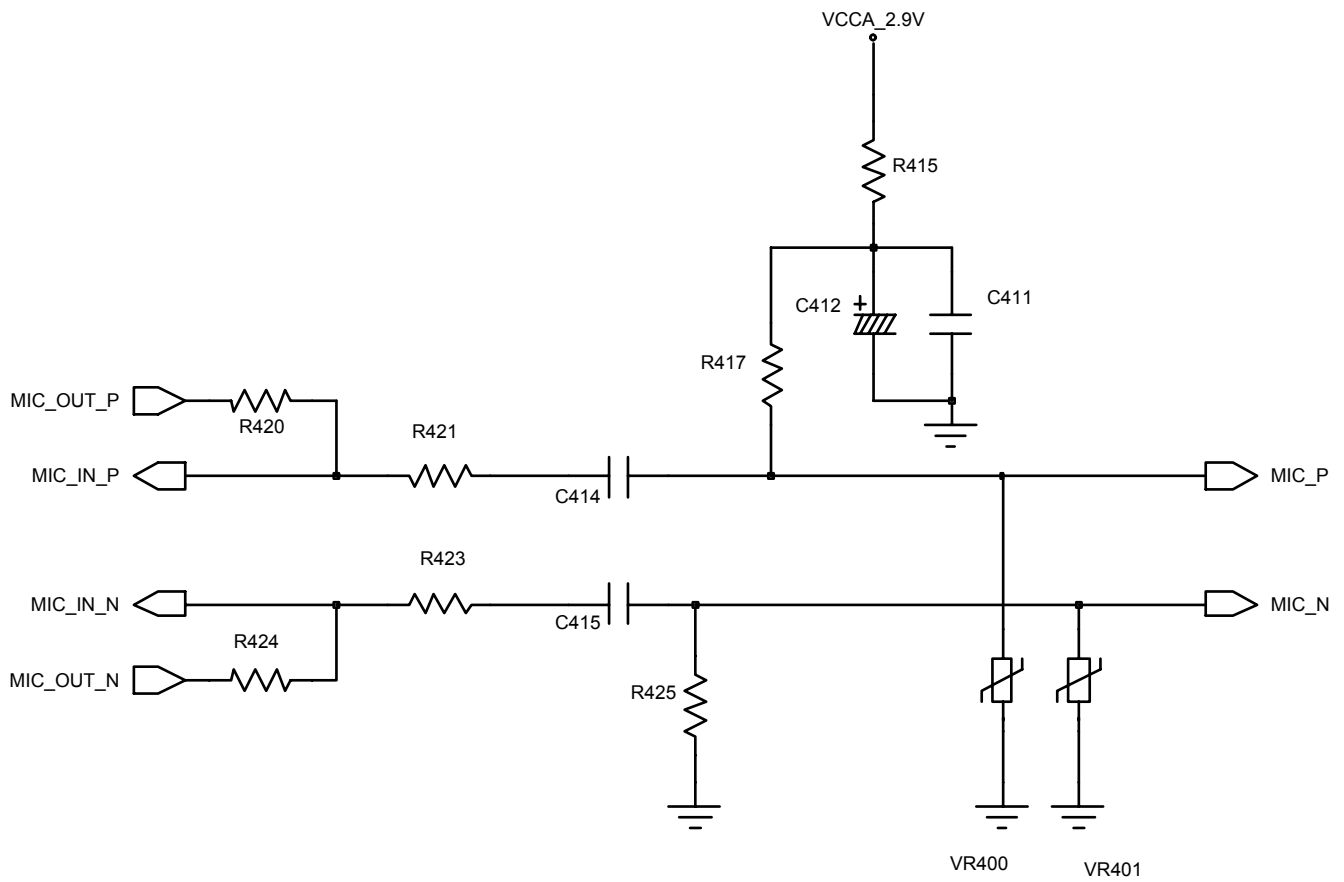

### 3-1-5. Receiver Part

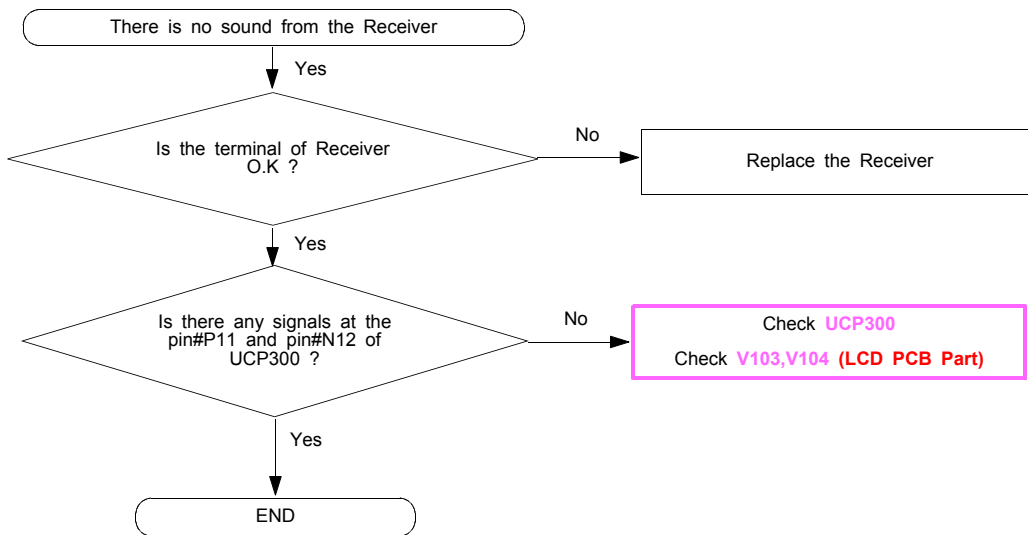

### 3-1-6. Speaker Part

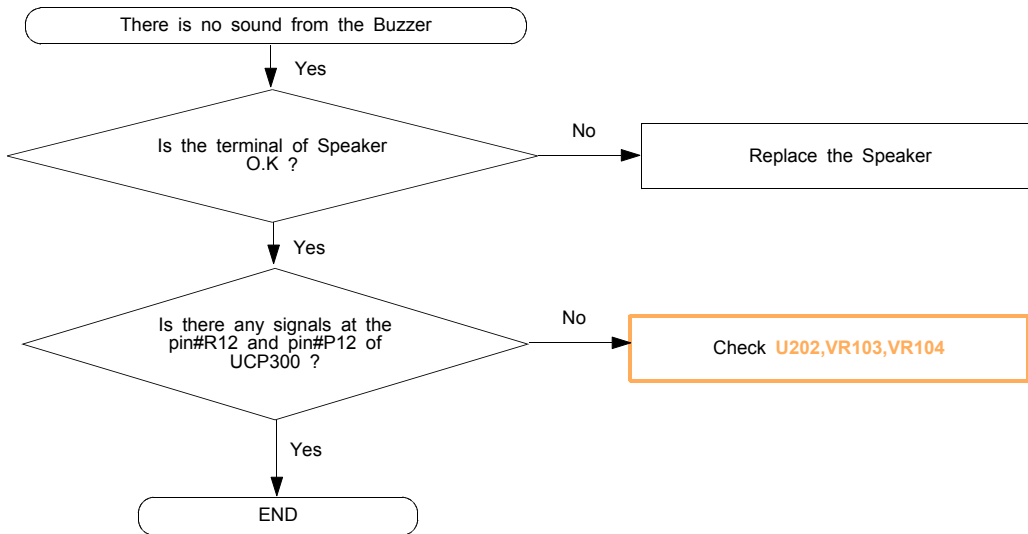

< LCD PCB Part >

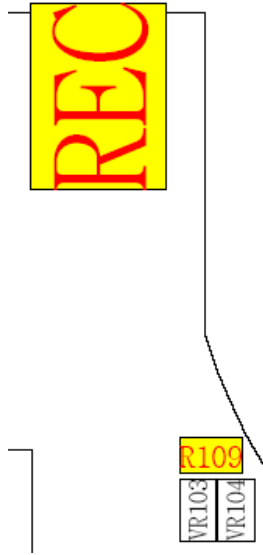

### 3-2.RF

#### 3-2-1. EGSM RX

CONTINUOUS RX ON  
RF INPUT : 62CH  
AMP : -50dBm

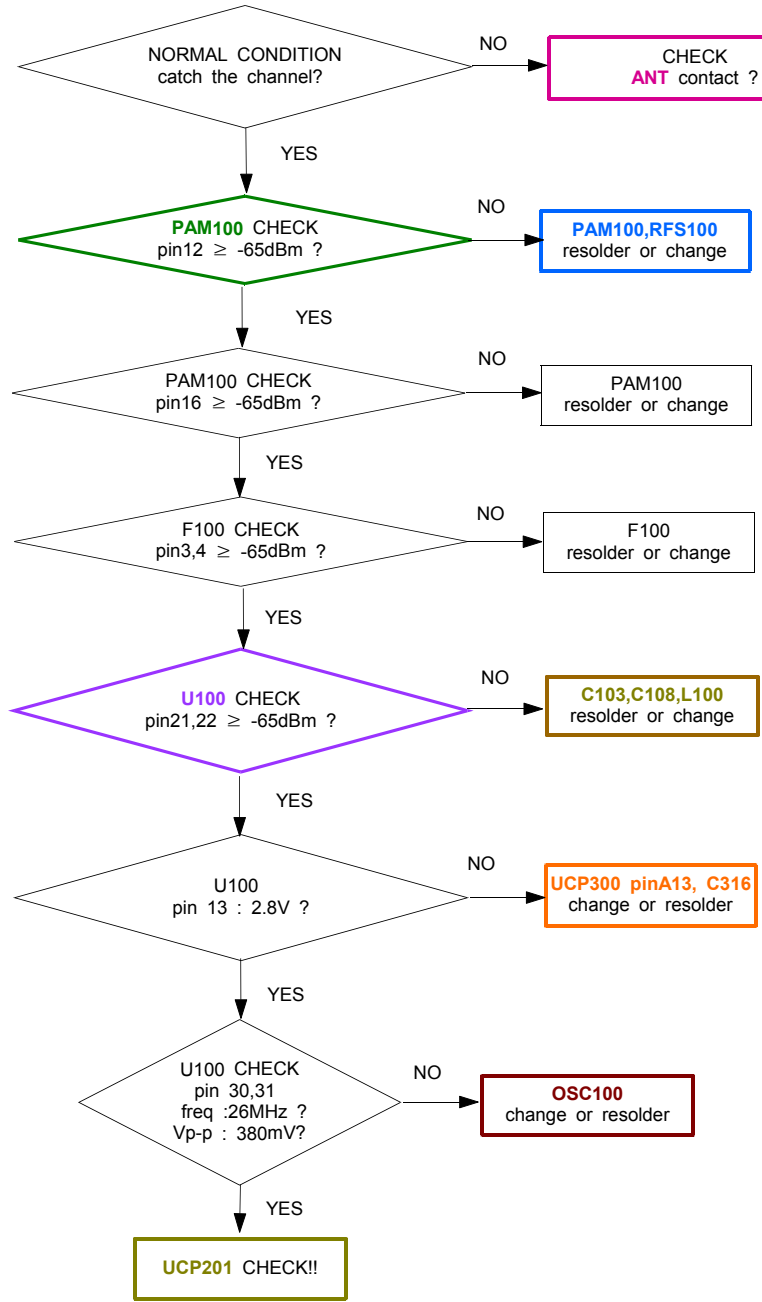

3-2-2. DCS RX

CONTINUOUS RX ON  
RF INPUT : 698CH  
AMP : -50dBm

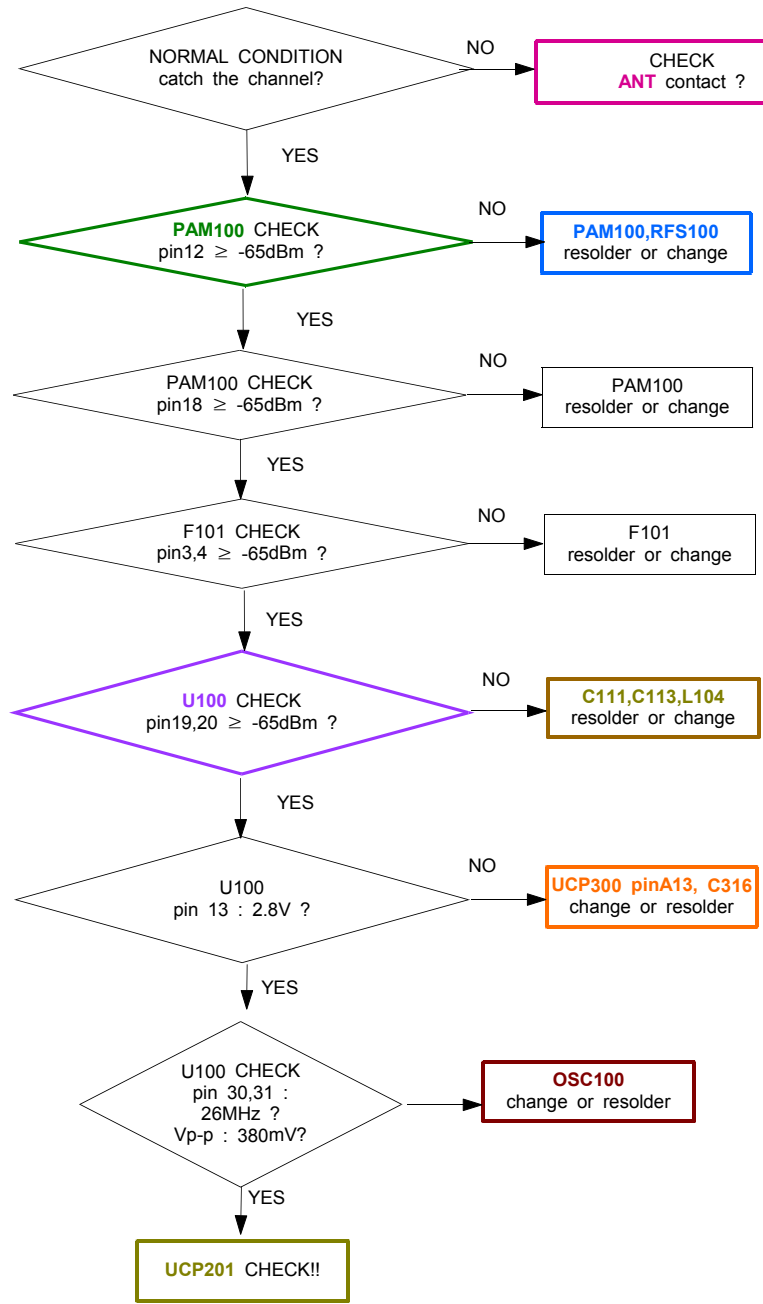

3-2-3. PCS RX

CONTINUOUS RX ON  
RF INPUT : 698CH  
AMP : -50dBm

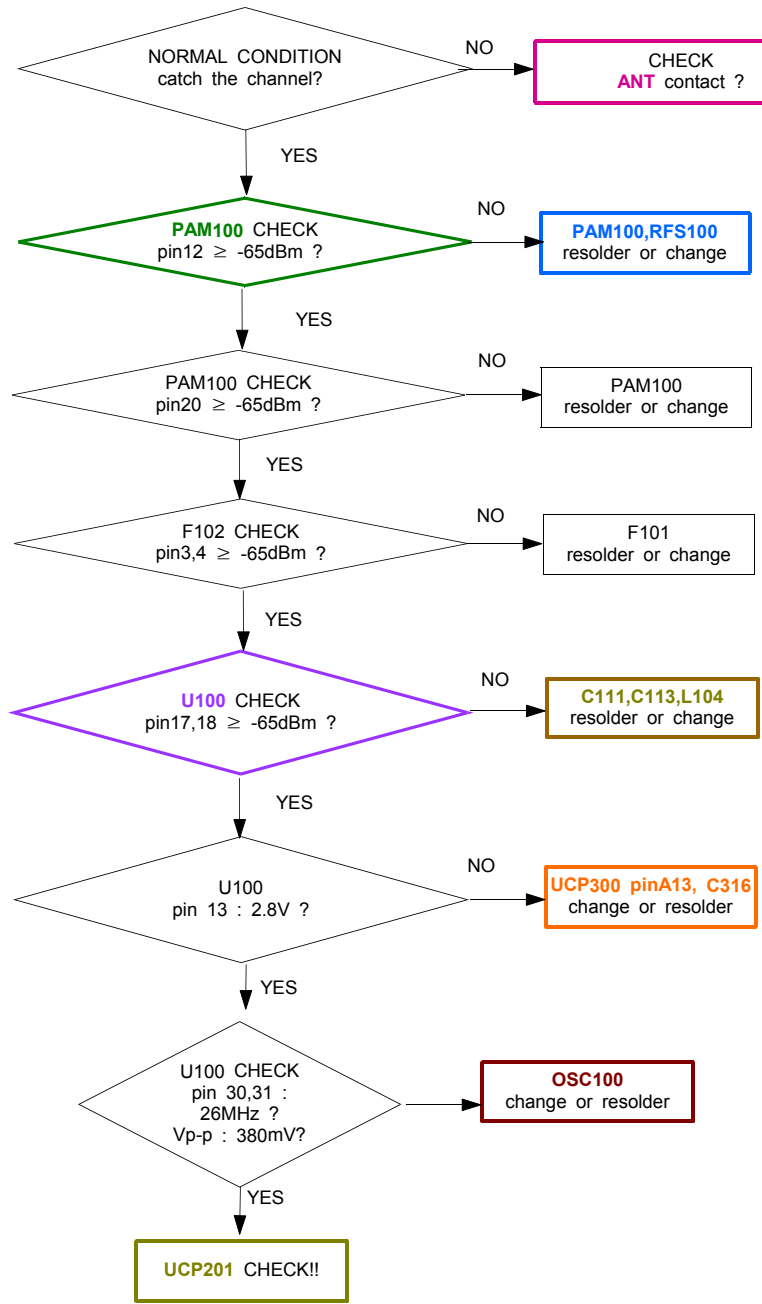

### 3-2-3. EGSM TX

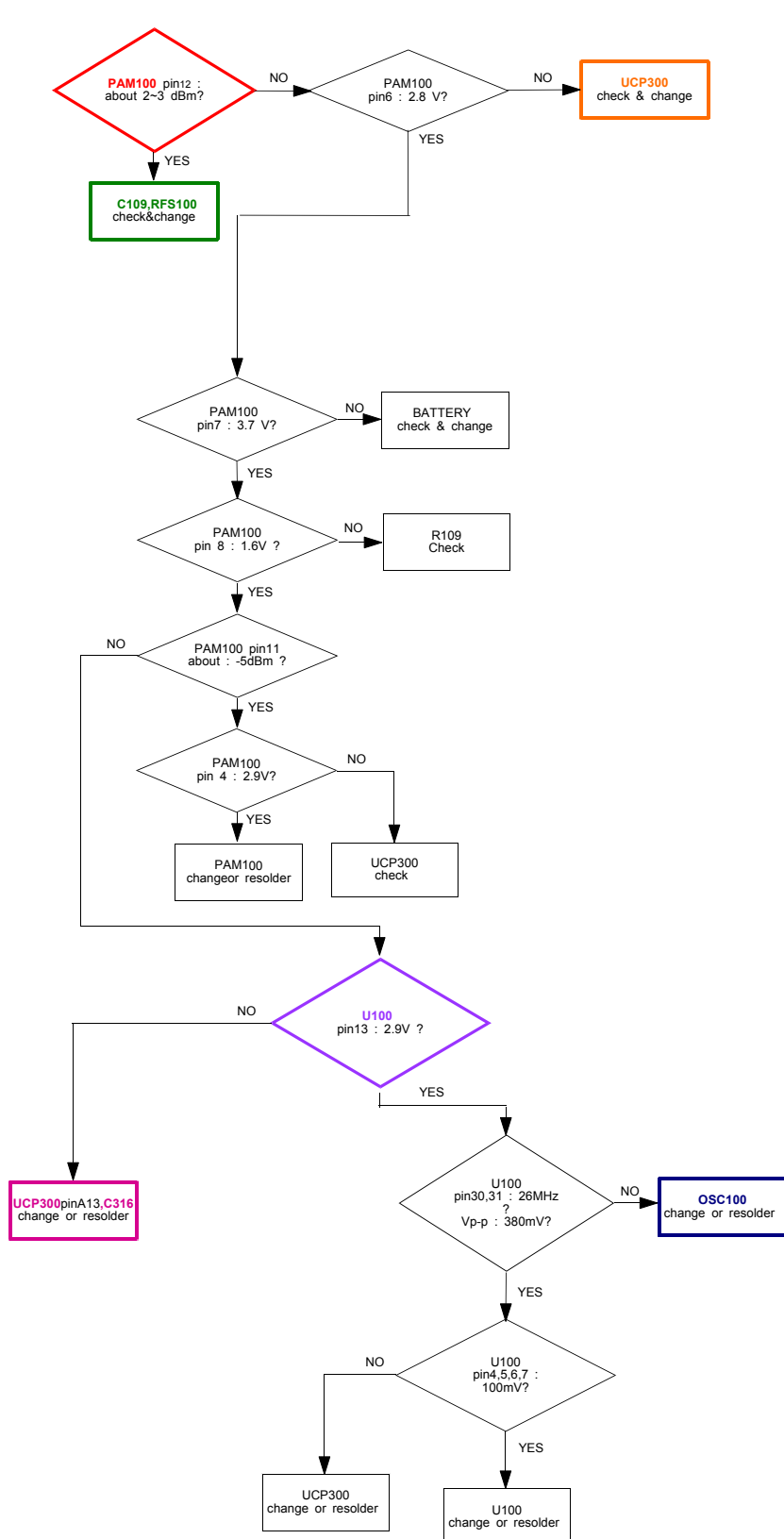

CONTINUOUS TX ON CONDITION  
 TX POWER DAC: 600 CODE APPLIED  
 CH : 62  
 RBW : 100KHz  
 VBW : 100KHz  
 SPAN : 10MHz  
 REF LEV : 10dBm  
 ATT : 20dB

3-2-4. DCS TX

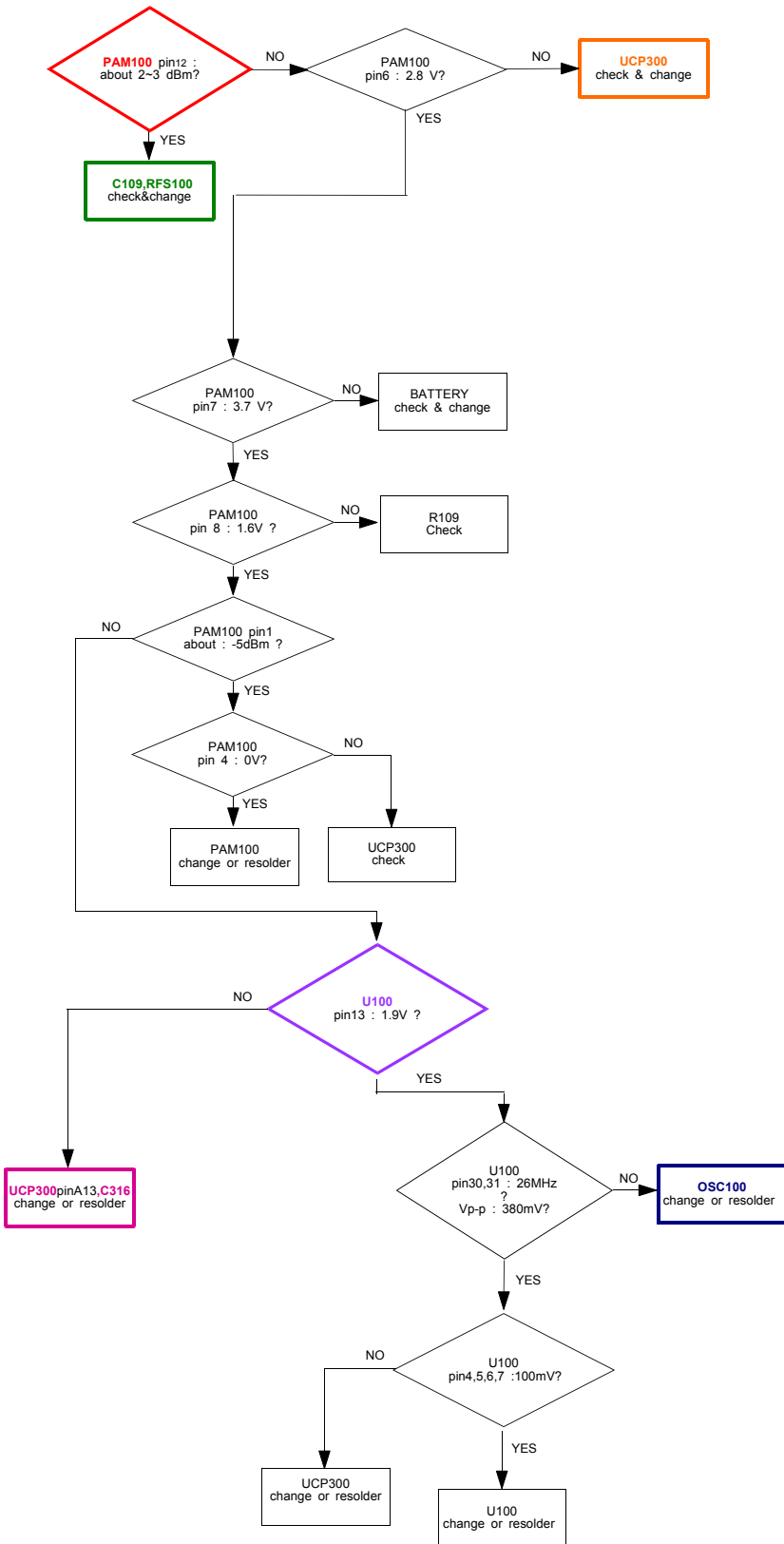

CONTINUOUS TX ON CONDITION  
 CH : 698CH(DCS)  
 TX POWER CODE: 520 CODE Applied  
 RBW : 100KHz  
 VBW : 100KHz  
 SPAN : 10MHz  
 REF LEV. : 10dBm  
 ATT. : 20dB



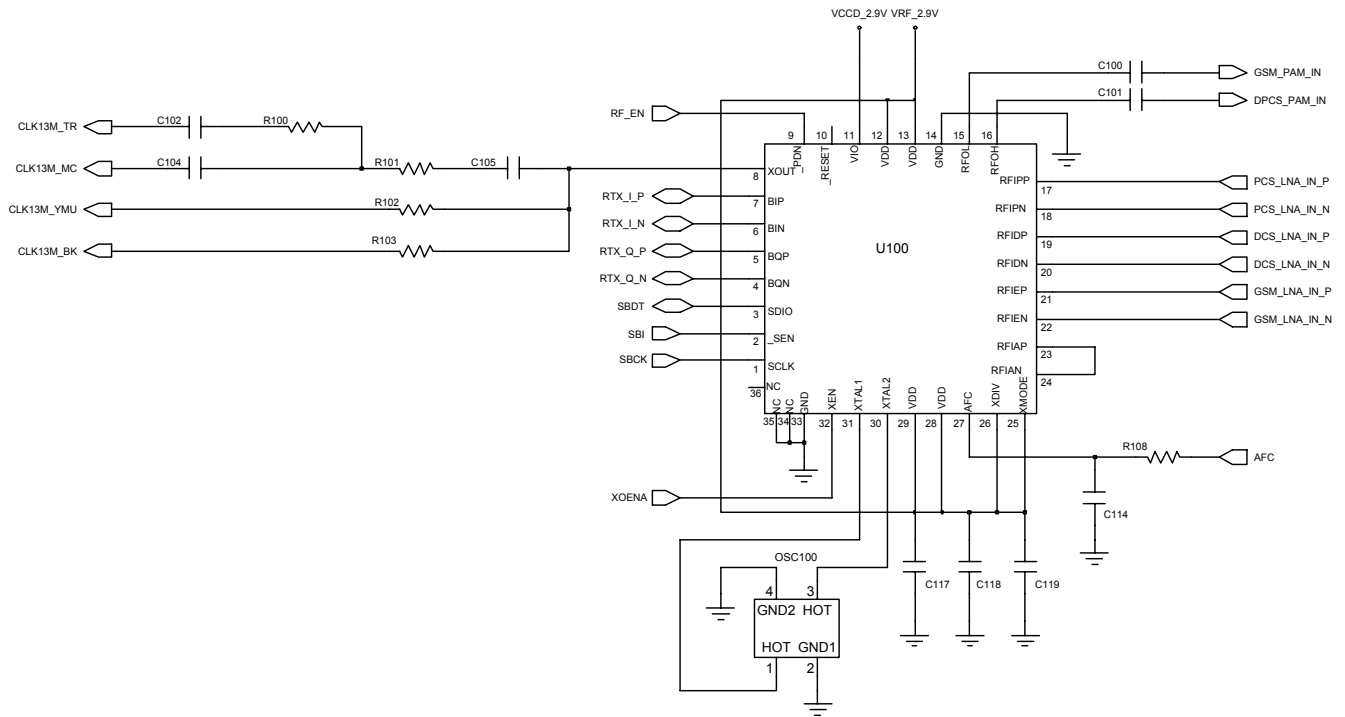

# Flow Chart of Troubleshooting

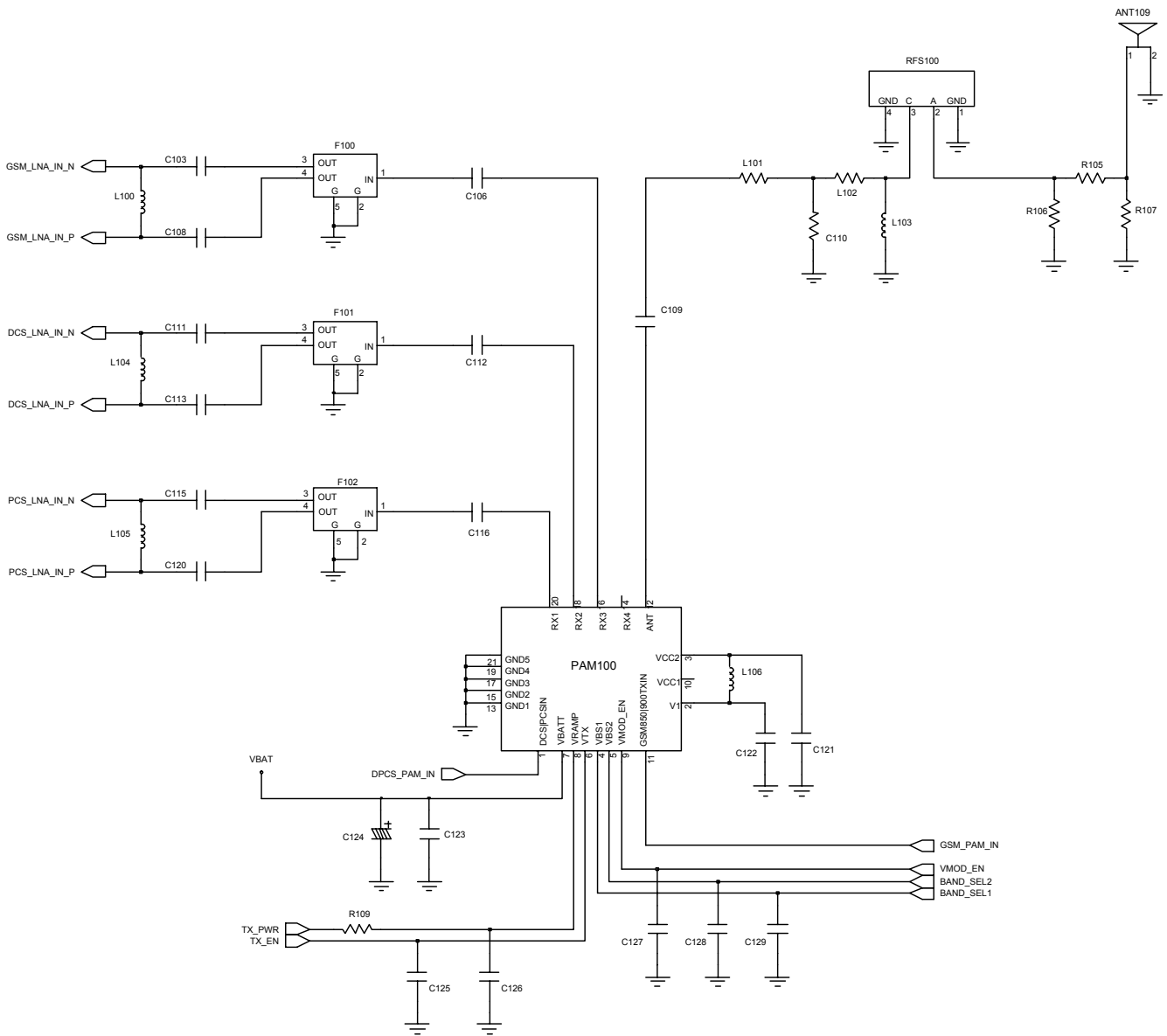

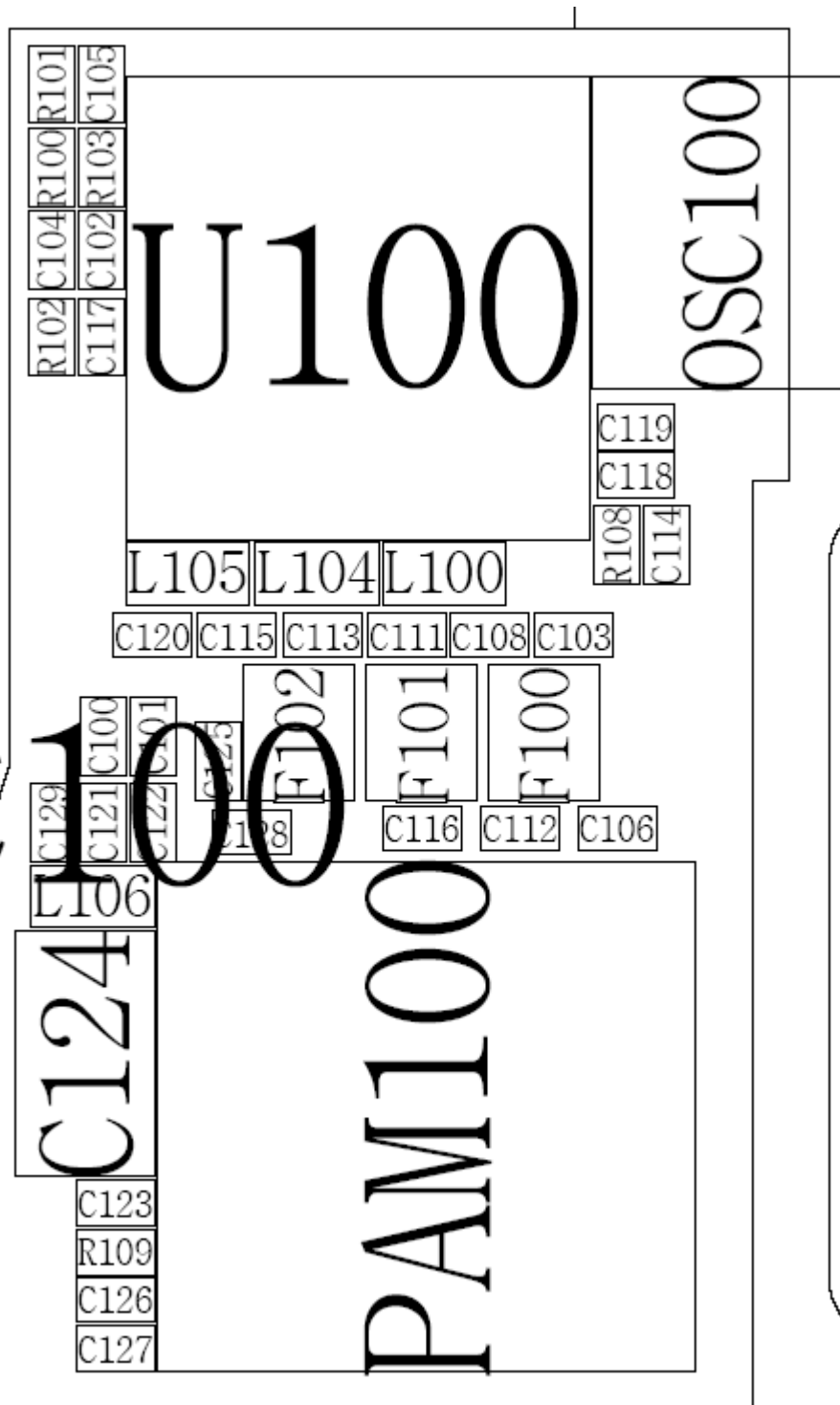

---

## 4. Array course control

---

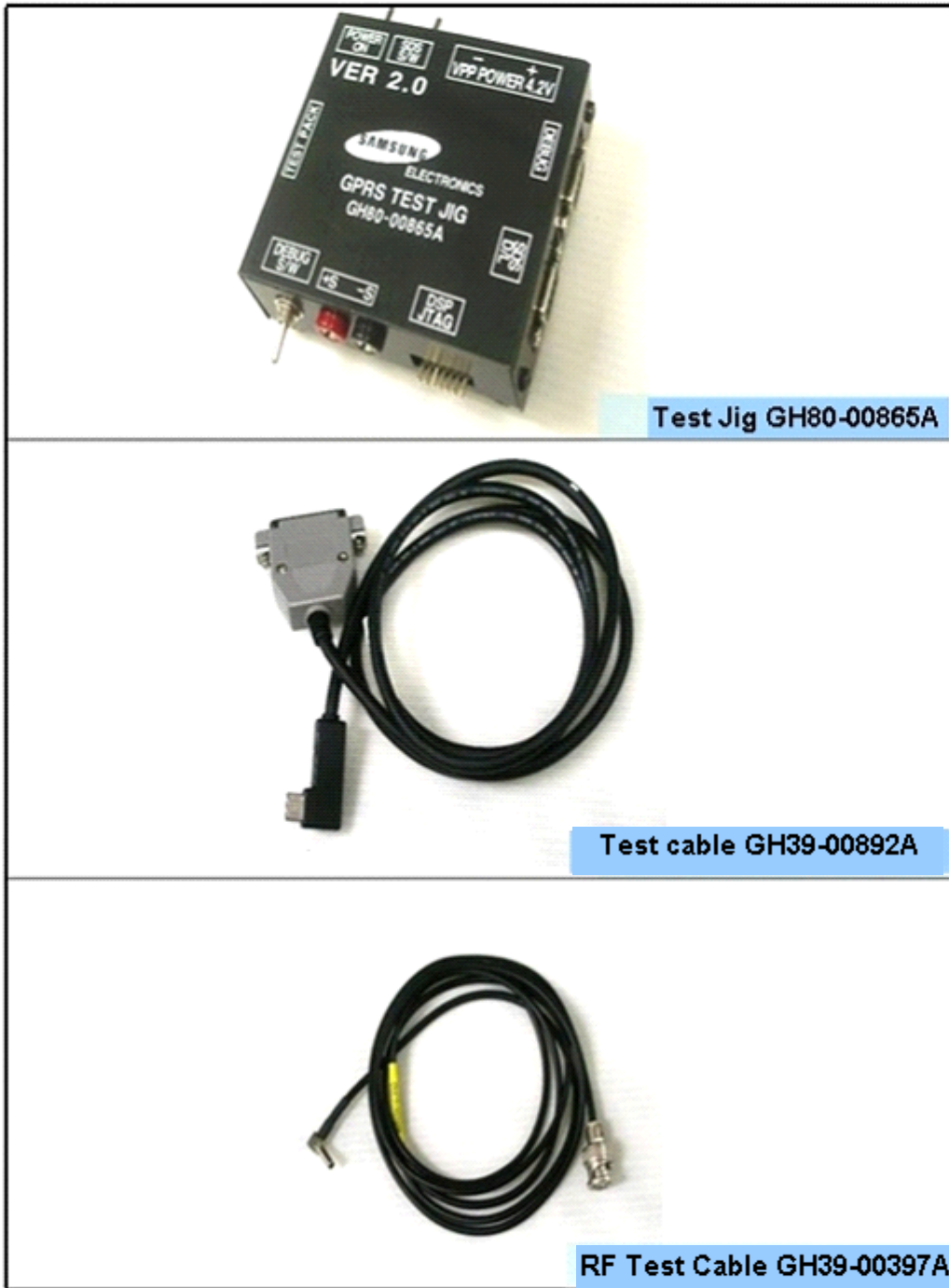

## Software Downloading

### 4-1. Downloading Binary Files

- Three binary files for downloading M600
  - M600SXXYY.s3 : Main source code binary

### 4-2. Pre-requisite for Downloading

- Downloader Program([OptiFlash.exe](#))
- M600S Mobile Phone
- Data Cable
- Binary files

### 4-3. S/W Downloader Program

1. Load the binary download program by executing the "Optiflash.exe"

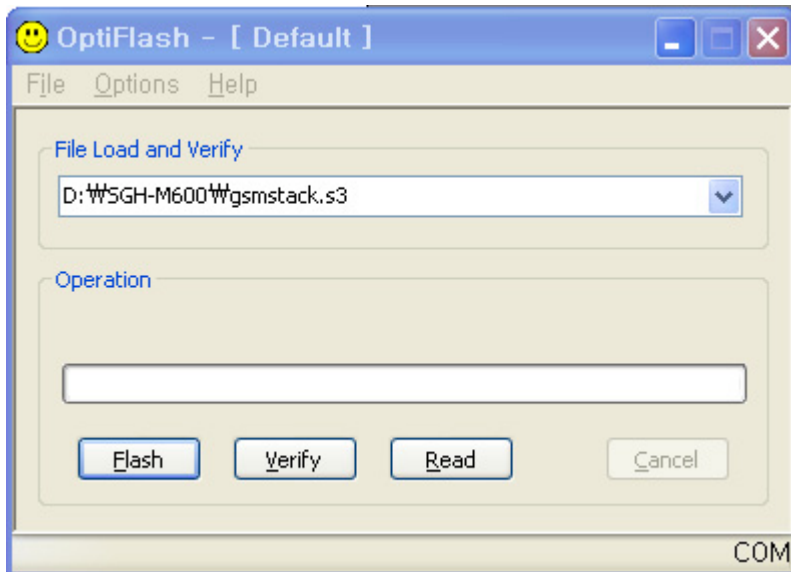

2. Select the "Options" → "Settings" → "Generic" → "Specify hardware platform".

Choose hardware platform for the downloader file setting.

Set the everything else as the default values which are shown below

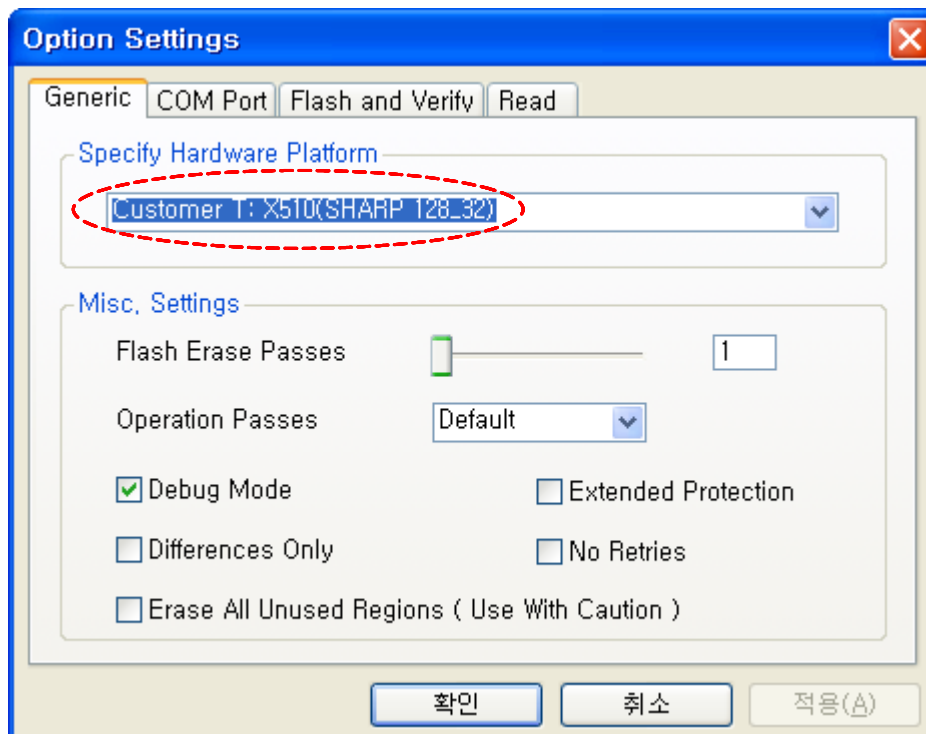

3. Select the **COM port** when the download cable is connected

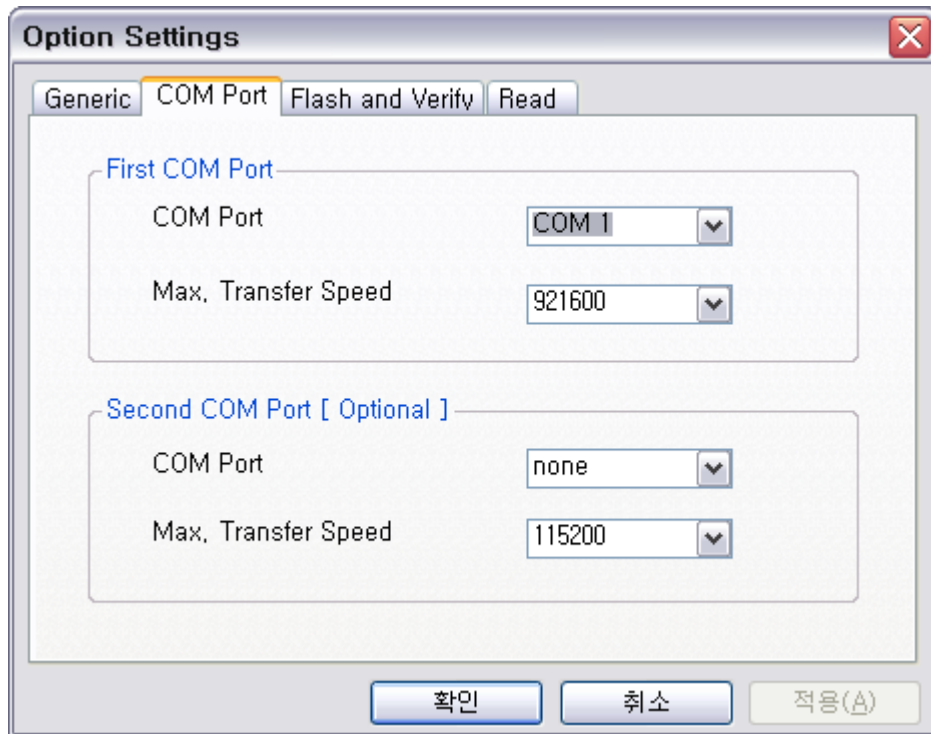

Additionally you can select the maximum transfer speed OptiFlash will use to communicate with the phone. However, OptiFlash will use a slower speed if either the PC's or the phone's serial hardware is incapable of handling the selected speed

4. Select the **"Flash&Verify"** → **"Browse"**

Set the directory path and choose the lastet s/w binary, for example "M600SXXYY.s3", for the downloader binary setting.

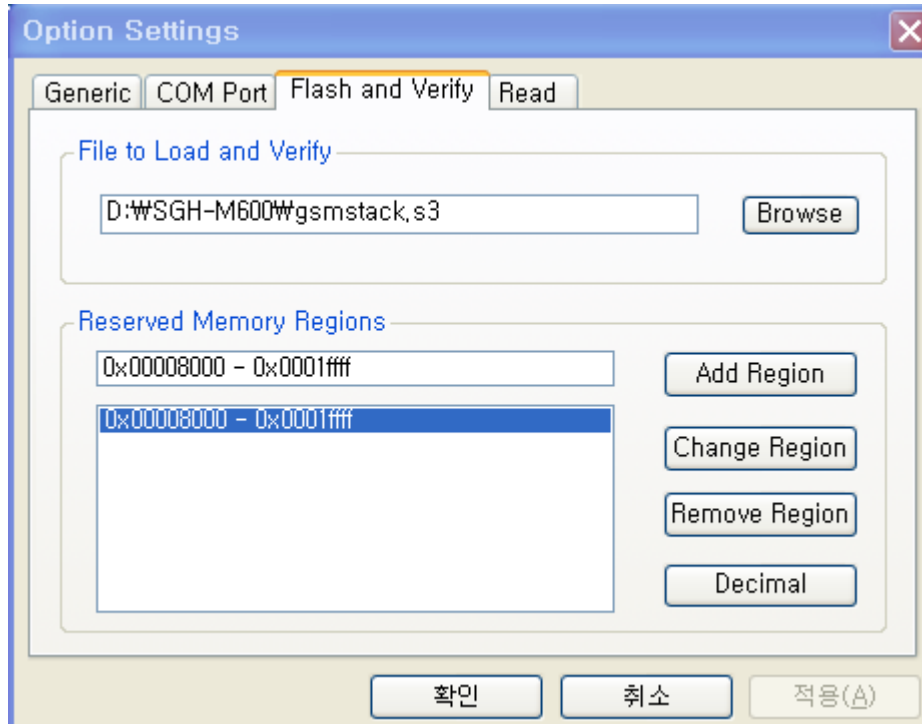

**Make sure that not to change the reserved memory regions.**

**In case of M600 the reserved regions are :**

- **0x00008000 - 0x0001ffff**



5. Click **"OK"** button then press **"Flash"**.  
(Before pressing 'Flash' button, push the button **"\*\*and 'END' at the same time.** Then press 'Flash'.)

Downloader will upload the binary file as below for the downloading.

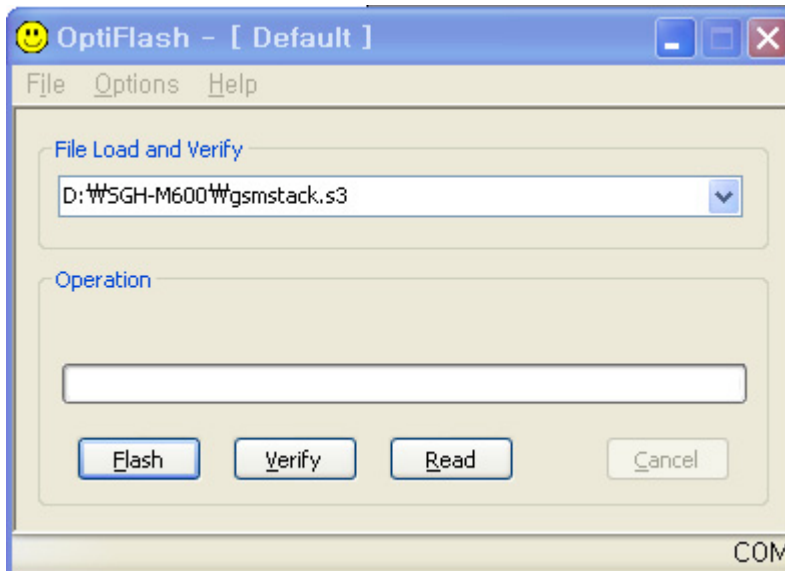

6. When downloading is finished successfully, there is a "All is well" message.
7. After finishing downloading, Certain memory resets should be done to guarantee the normal performance.
8. Confirm the downloaded version name and etc. :  
**\*#1234#**  
Full Reset :  
**\*0206\*3855#**

## 5. Block Diagrams

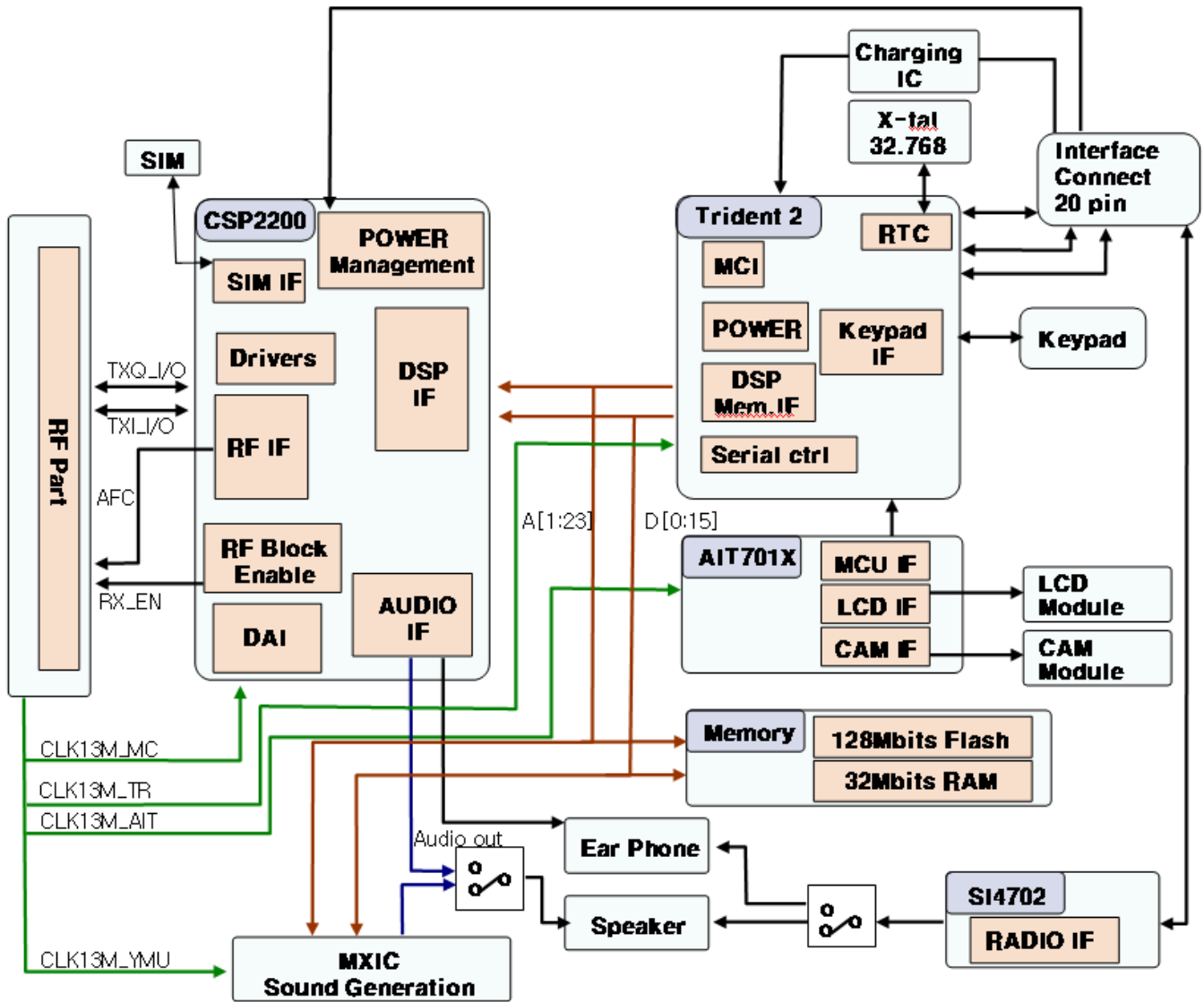

## 5. Block Diagrams

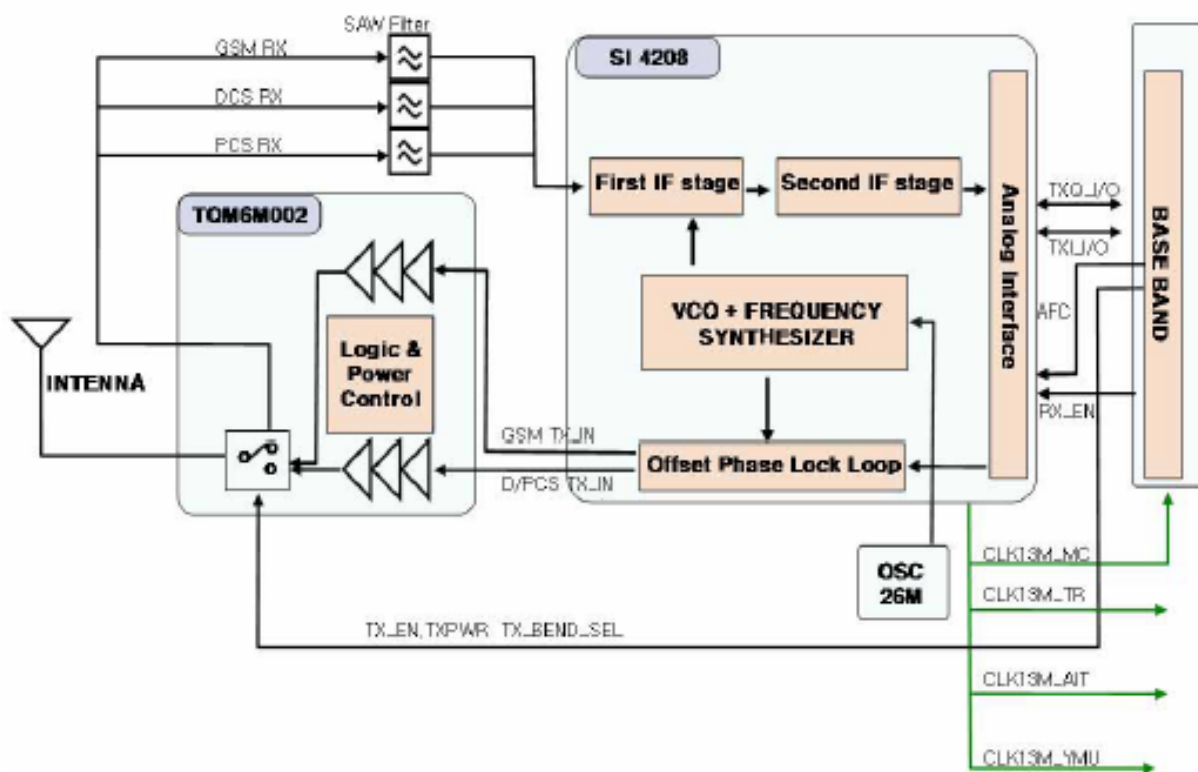

## 6. PCB Diagrams

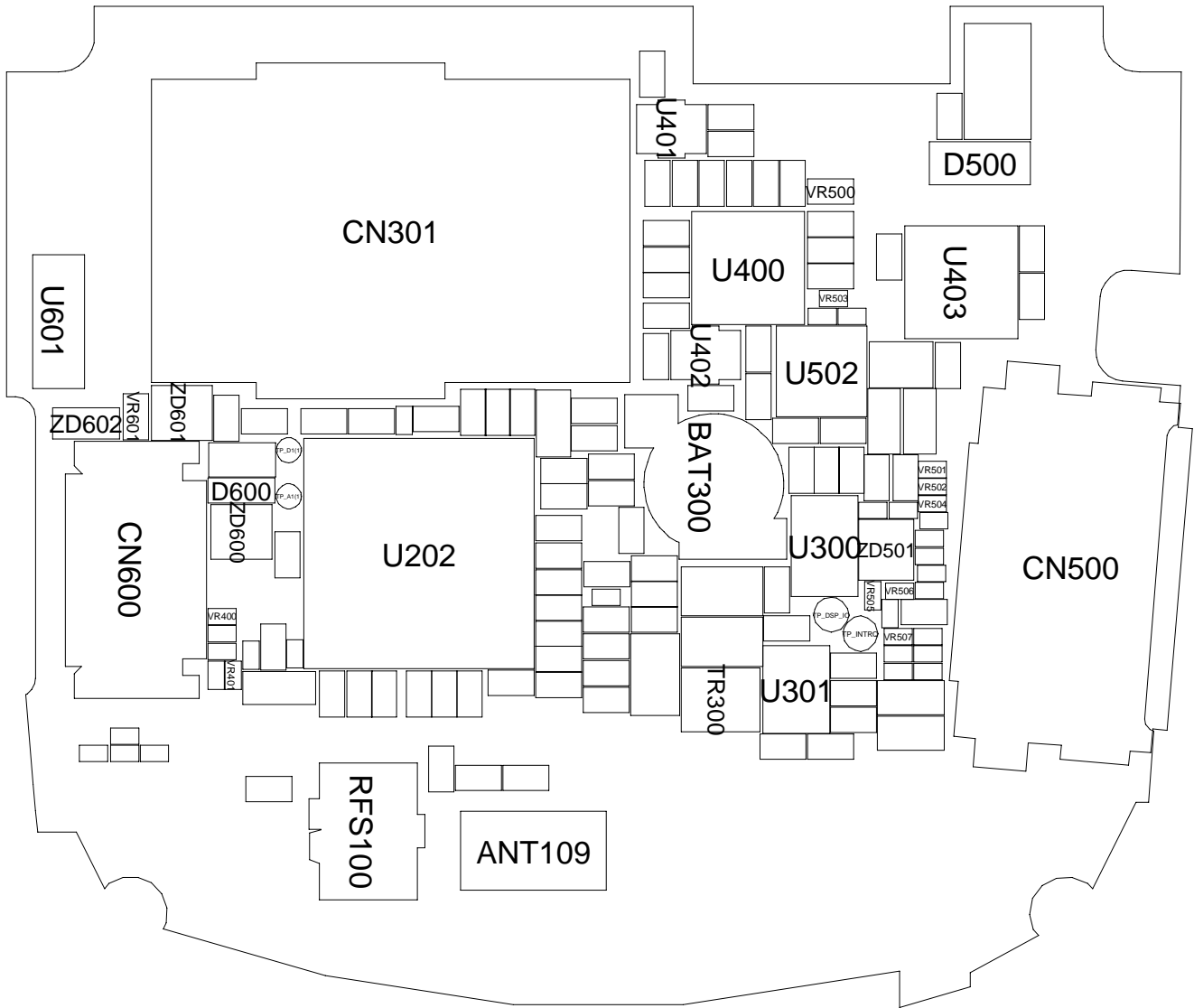

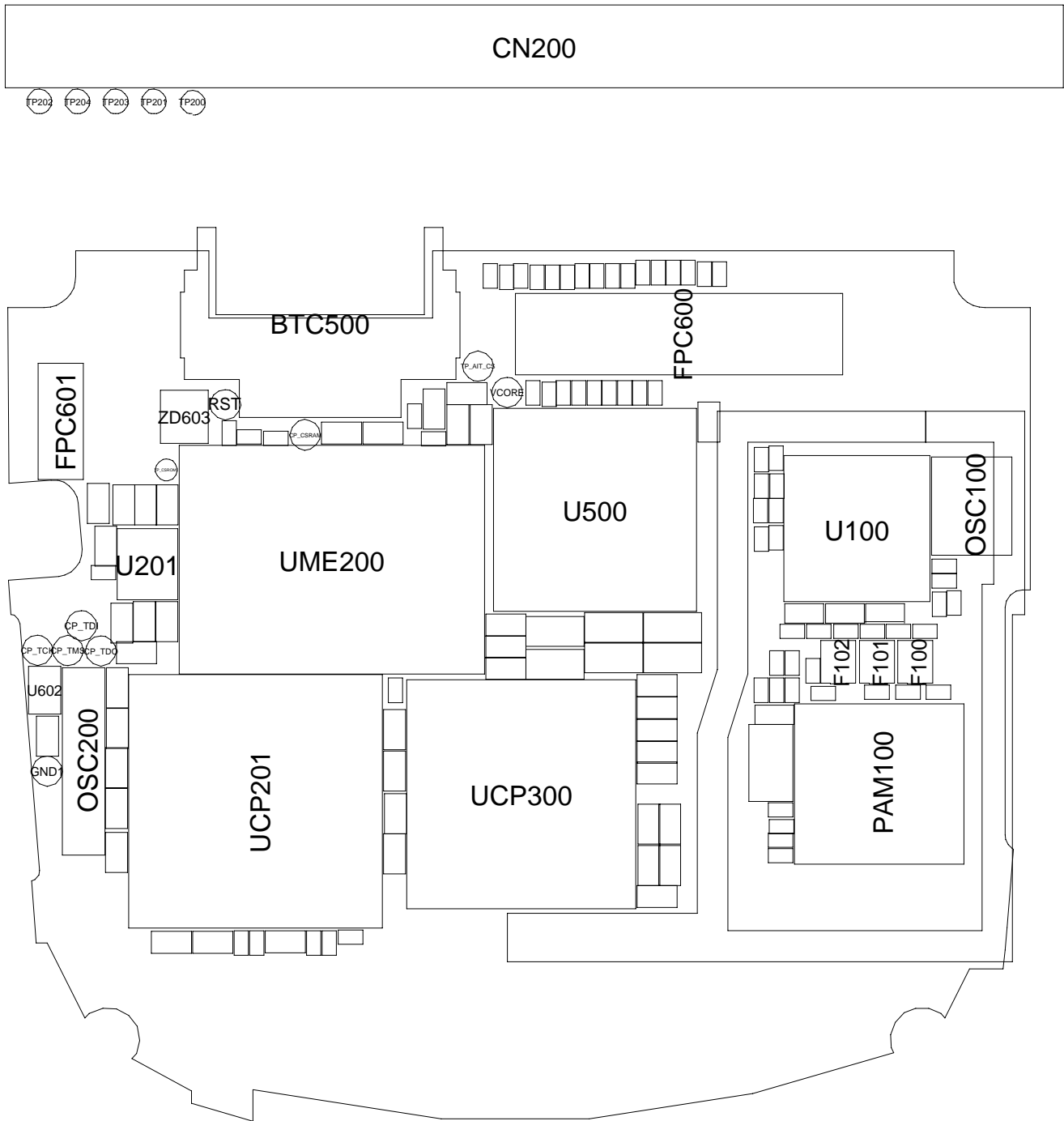

## 7. MAIN Electrical Parts List

SEC CODE	Design LOC	Discription	STATUS
0401-001141	D600	DIODE-SWITCHING	SA
0403-001547	D500	DIODE-ZENER	SA
0406-001190	ZD501	DIODE-TVS	SA
0406-001190	ZD600	DIODE-TVS	SA
0406-001190	ZD601	DIODE-TVS	SA
0406-001190	ZD603	DIODE-TVS	SA
0406-001201	ZD602	DIODE-TVS	SA
0504-000168	TR300	TR-DIGITAL	SA
0801-002529	U301	IC-CMOS LOGIC	SA
1001-001349	U502	IC-ANALOG MULTIPLEX	SA
1001-001428	U401	IC-ANALOG MULTIPLEX	SA
1001-001428	U402	IC-ANALOG MULTIPLEX	SA
1009-001020	U201	IC-HALL EFFECT S/W	SA
1108-000111	UME200	IC-MCP	SA
1201-002180	U400	IC-AUDIO AMP	SA
1201-002278	PAM100	IC-POWER AMP	SA
1203-003304	UCP300	IC-POWER SUPERVISOR	SA
1203-003663	U300	IC-BATTERY	SA
1204-002700	U403	IC-TUNER	SA
1204-002783	U202	IC-SOUND GENERATOR	SA
1205-003116	U100	IC-TRANSCEIVER	SA
1209-001712	U602	IC-SENSOR	SA
1405-001082	VR500	VARISTOR	SA
1405-001082	VR601	VARISTOR	SA
1405-001177	VR501	VARISTOR	SA
1405-001177	VR502	VARISTOR	SA
1405-001177	VR503	VARISTOR	SA
1405-001177	VR504	VARISTOR	SA
1405-001177	VR505	VARISTOR	SA
1405-001177	VR506	VARISTOR	SA
1405-001177	VR507	VARISTOR	SA
1405-001200	VR400	VARISTOR	SA
1405-001200	VR401	VARISTOR	SA
2007-000138	R606	R-CHIP	SA
2007-000141	R401	R-CHIP	SA
2007-000143	R218	R-CHIP	SA
2007-000143	R219	R-CHIP	SA

SEC CODE	Design LOC	Discription	STATUS
2007-000144	R302	R-CHIP	SA
2007-000148	R407	R-CHIP	SA
2007-000148	R408	R-CHIP	SA
2007-000148	R409	R-CHIP	SA
2007-000148	R412	R-CHIP	SA
2007-000148	R421	R-CHIP	SA
2007-000148	R423	R-CHIP	SA
2007-000157	R205	R-CHIP	SA
2007-000157	R413	R-CHIP	SA
2007-000157	R414	R-CHIP	SA
2007-000157	R426	R-CHIP	SA
2007-000160	R210	R-CHIP	SA
2007-000161	R405	R-CHIP	SA
2007-000161	R411	R-CHIP	SA
2007-000162	R206	R-CHIP	SA
2007-000162	R301	R-CHIP	SA
2007-000162	R307	R-CHIP	SA
2007-000170	R215	R-CHIP	SA
2007-000171	R105	R-CHIP	SA
2007-000172	R305	R-CHIP	SA
2007-000242	R402	R-CHIP	SA
2007-000775	R211	R-CHIP	SA
2007-000831	R403	R-CHIP	SA
2007-000831	R404	R-CHIP	SA
2007-001119	R400	R-CHIP	SA
2007-001325	R217	R-CHIP	SA
2007-003010	R406	R-CHIP	SA
2007-003010	R410	R-CHIP	SA
2007-007107	R214	R-CHIP	SA
2007-007107	R431	R-CHIP	SA
2007-007138	R303	R-CHIP	SA
2007-007468	R420	R-CHIP	SA
2007-007468	R424	R-CHIP	SA
2007-007529	R308	R-CHIP	SA
2007-007538	R306	R-CHIP	SA
2007-007573	R213	R-CHIP	SA
2007-007573	R216	R-CHIP	SA

SEC CODE	Design LOC	Discription	STATUS
2007-008055	R501	R-CHIP	SA
2007-008055	R505	R-CHIP	SA
2007-008055	R506	R-CHIP	SA
2007-008419	R507	R-CHIP	SA
2007-008419	R508	R-CHIP	SA
2007-008419	R509	R-CHIP	SA
2007-008419	R510	R-CHIP	SA
2007-008419	R511	R-CHIP	SA
2007-008419	R515	R-CHIP	SA
2007-008419	R516	R-CHIP	SA
2007-008483	R212	R-CHIP	SA
2007-008483	R504	R-CHIP	SA
2007-008483	R601	R-CHIP	SA
2007-008516	R108	R-CHIP	SA
2007-008516	R109	R-CHIP	SA
2007-008531	R200	R-CHIP	SA
2007-008531	R201	R-CHIP	SA
2007-008531	R600	R-CHIP	SA
2007-008542	L101	R-CHIP	SA
2007-008542	L102	R-CHIP	SA
2007-008542	R102	R-CHIP	SA
2007-008542	R103	R-CHIP	SA
2007-008542	R518	R-CHIP	SA
2007-008544	R415	R-CHIP	SA
2007-008587	R100	R-CHIP	SA
2007-008587	R101	R-CHIP	SA
2007-008588	R425	R-CHIP	SA
2007-008786	R202	R-CHIP	SA
2007-009084	R500	R-CHIP	SA
2007-009084	R502	R-CHIP	SA
2007-009160	R304	R-CHIP	SA
2007-009168	R203	R-CHIP	SA
2007-009208	R519	R-CHIP	SA
2007-009208	R520	R-CHIP	SA
2007-009315	R204	R-CHIP	SA
2007-009315	R300	R-CHIP	SA
2007-009402	R417	R-CHIP	SA



SEC CODE	Design LOC	Discription	STATUS
2203-000189	C509	C-CER,CHIP	SA
2203-000233	C319	C-CER,CHIP	SA
2203-000233	C421	C-CER,CHIP	SA
2203-000254	C218	C-CER,CHIP	SA
2203-000254	C306	C-CER,CHIP	SA
2203-000254	C307	C-CER,CHIP	SA
2203-000359	C222	C-CER,CHIP	SA
2203-000386	C237	C-CER,CHIP	SA
2203-000386	C238	C-CER,CHIP	SA
2203-000438	C233	C-CER,CHIP	SA
2203-000679	C217	C-CER,CHIP	SA
2203-000812	C301	C-CER,CHIP	SA
2203-000812	C302	C-CER,CHIP	SA
2203-000812	C405	C-CER,CHIP	SA
2203-000812	C406	C-CER,CHIP	SA
2203-000812	C416	C-CER,CHIP	SA
2203-000812	C418	C-CER,CHIP	SA
2203-000940	C304	C-CER,CHIP	SA
2203-000995	C220	C-CER,CHIP	SA
2203-000995	C300	C-CER,CHIP	SA
2203-005344	C216	C-CER,CHIP	SA
2203-005344	C320	C-CER,CHIP	SA
2203-005682	C101	C-CER,CHIP	SA
2203-005682	C102	C-CER,CHIP	SA
2203-005682	C125	C-CER,CHIP	SA
2203-005682	C127	C-CER,CHIP	SA
2203-005682	C128	C-CER,CHIP	SA
2203-005682	C129	C-CER,CHIP	SA
2203-005682	C425	C-CER,CHIP	SA
2203-005731	C106	C-CER,CHIP	SA
2203-005734	C234	C-CER,CHIP	SA
2203-005736	C104	C-CER,CHIP	SA
2203-005736	C112	C-CER,CHIP	SA
2203-005736	C116	C-CER,CHIP	SA
2203-005736	C126	C-CER,CHIP	SA
2203-005777	C103	C-CER,CHIP	SA
2203-005777	C108	C-CER,CHIP	SA

SEC CODE	Design LOC	Discription	STATUS
2203-005777	C111	C-CER,CHIP	SA
2203-005777	C113	C-CER,CHIP	SA
2203-005819	C314	C-CER,CHIP	SA
2203-005819	C315	C-CER,CHIP	SA
2203-005819	C316	C-CER,CHIP	SA
2203-005819	C317	C-CER,CHIP	SA
2203-005819	C318	C-CER,CHIP	SA
2203-006048	C203	C-CER,CHIP	SA
2203-006048	C207	C-CER,CHIP	SA
2203-006048	C208	C-CER,CHIP	SA
2203-006048	C209	C-CER,CHIP	SA
2203-006048	C210	C-CER,CHIP	SA
2203-006048	C211	C-CER,CHIP	SA
2203-006048	C215	C-CER,CHIP	SA
2203-006048	C225	C-CER,CHIP	SA
2203-006048	C226	C-CER,CHIP	SA
2203-006048	C227	C-CER,CHIP	SA
2203-006048	C228	C-CER,CHIP	SA
2203-006048	C229	C-CER,CHIP	SA
2203-006048	C230	C-CER,CHIP	SA
2203-006048	C232	C-CER,CHIP	SA
2203-006048	C235	C-CER,CHIP	SA
2203-006048	C240	C-CER,CHIP	SA
2203-006048	C305	C-CER,CHIP	SA
2203-006048	C322	C-CER,CHIP	SA
2203-006048	C422	C-CER,CHIP	SA
2203-006048	C507	C-CER,CHIP	SA
2203-006048	C616	C-CER,CHIP	SA
2203-006137	C221	C-CER,CHIP	SA
2203-006137	C423	C-CER,CHIP	SA
2203-006141	C504	C-CER,CHIP	SA
2203-006141	C505	C-CER,CHIP	SA
2203-006194	C105	C-CER,CHIP	SA
2203-006194	C114	C-CER,CHIP	SA
2203-006194	C121	C-CER,CHIP	SA
2203-006257	C241	C-CER,CHIP	SA
2203-006257	C303	C-CER,CHIP	SA

SEC CODE	Design LOC	Discription	STATUS
2203-006257	C313	C-CER,CHIP	SA
2203-006257	C411	C-CER,CHIP	SA
2203-006257	C424	C-CER,CHIP	SA
2203-006260	C205	C-CER,CHIP	SA
2203-006260	C206	C-CER,CHIP	SA
2203-006307	C324	C-CER,CHIP	SA
2203-006318	C115	C-CER,CHIP	SA
2203-006318	C120	C-CER,CHIP	SA
2203-006324	C308	C-CER,CHIP	SA
2203-006377	C311	C-CER,CHIP	SA
2203-006423	C117	C-CER,CHIP	SA
2203-006423	C119	C-CER,CHIP	SA
2203-006423	C122	C-CER,CHIP	SA
2203-006423	C123	C-CER,CHIP	SA
2203-006423	C219	C-CER,CHIP	SA
2203-006423	C414	C-CER,CHIP	SA
2203-006423	C415	C-CER,CHIP	SA
2203-006423	C500	C-CER,CHIP	SA
2203-006423	C503	C-CER,CHIP	SA
2203-006423	C602	C-CER,CHIP	SA
2203-006423	C603	C-CER,CHIP	SA
2203-006466	C508	C-CER,CHIP	SA
2203-006474	C400	C-CER,CHIP	SA
2203-006556	C100	C-CER,CHIP	SA
2203-006556	C109	C-CER,CHIP	SA
2203-006556	C600	C-CER,CHIP	SA
2203-006556	C604	C-CER,CHIP	SA
2203-006556	C605	C-CER,CHIP	SA
2203-006556	C606	C-CER,CHIP	SA
2203-006556	C607	C-CER,CHIP	SA
2203-006556	C608	C-CER,CHIP	SA
2203-006556	C609	C-CER,CHIP	SA
2203-006556	C610	C-CER,CHIP	SA
2203-006556	C611	C-CER,CHIP	SA
2203-006556	C612	C-CER,CHIP	SA
2203-006556	C613	C-CER,CHIP	SA
2203-006556	C614	C-CER,CHIP	SA

SEC CODE	Design LOC	Discription	STATUS
2203-006562	C236	C-CER,CHIP	SA
2203-006562	C309	C-CER,CHIP	SA
2203-006562	C312	C-CER,CHIP	SA
2203-006562	C321	C-CER,CHIP	SA
2203-006562	C323	C-CER,CHIP	SA
2203-006562	C402	C-CER,CHIP	SA
2203-006562	C403	C-CER,CHIP	SA
2203-006562	C407	C-CER,CHIP	SA
2203-006562	C408	C-CER,CHIP	SA
2203-006562	C409	C-CER,CHIP	SA
2203-006562	C410	C-CER,CHIP	SA
2203-006562	C417	C-CER,CHIP	SA
2203-006562	C501	C-CER,CHIP	SA
2203-006562	C502	C-CER,CHIP	SA
2203-006562	C510	C-CER,CHIP	SA
2203-006562	C601	C-CER,CHIP	SA
2203-006626	C401	C-CER,CHIP	SA
2203-006626	C404	C-CER,CHIP	SA
2203-006648	C118	C-CER,CHIP	SA
2203-006648	C511	C-CER,CHIP	SA
2203-006681	C310	C-CER,CHIP	SA
2203-006824	C223	C-CER,CHIP	SA
2203-006824	C617	C-CER,CHIP	SA
2203-006838	C615	C-CER,CHIP	SA
2203-006872	C224	C-CER,CHIP	SA
2203-006979	C200	C-CER,CHIP	SA
2203-006979	C201	C-CER,CHIP	SA
2203-006979	C202	C-CER,CHIP	SA
2203-006979	C204	C-CER,CHIP	SA
2203-006979	C212	C-CER,CHIP	SA
2203-006979	C213	C-CER,CHIP	SA
2203-006979	C214	C-CER,CHIP	SA
2203-006979	C513	C-CER,CHIP	SA
2404-001374	C124	C-TA,CHIP	SA
2404-001377	C412	C-TA,CHIP	SA
2404-001406	C506	C-TA,CHIP	SA
2703-002313	L103	INDUCTOR-SMD	SA

SEC CODE	Design LOC	Discription	STATUS
2703-002367	L201	INDUCTOR-SMD	SA
2703-002485	L100	INDUCTOR-SMD	SA
2703-002544	L105	INDUCTOR-SMD	SA
2703-002558	L106	INDUCTOR-SMD	SA
2703-002597	L104	INDUCTOR-SMD	SA
2703-003196	L500	INDUCTOR-SMD	SA
2801-003856	OSC200	CRYSTAL-SMD	SA
2801-004587	OSC100	CRYSTAL-SMD	SA
2904-001592	F100	FILTER-SAW	SA
2904-001599	F101	FILTER-SAW	SA
2904-001600	F102	FILTER-SAW	SA
3301-001342	L200	BEAD-SMD	SA
3301-001729	L501	BEAD-SMD	SA
3301-001729	L502	BEAD-SMD	SA
3301-001729	L503	BEAD-SMD	SA
3301-001729	L504	BEAD-SMD	SA
3705-001421	RFS100	CONNECTOR-COAXIAL	SA
3708-002211	CN600	CONNECTOR-FPC/FFC/PIC	SA
3709-001391	SIM301	CONNECTOR-CARD EDGE	SA
3710-002499	IFC500	SOCKET-INTERFACE	SA
3711-006348	BTC500	HEADER-BATTERY	SA
3711-006483	FPC600	HEADER-BOARD TO BOARD	SA
4302-001130	BAT300	BATTERY-LI(2ND)	SA
GH09-00036A	UCP201	IC MICOM-SGHX480	SA
GH13-00050A	U500	IC ASIC-SGHC510	SA
GH70-02466A	SC100	IPR SHIELD-SMD	SA

---

## 8. Reference data

---

### 8-1. Reference Abbreviate

**AAC:** Advanced Audio Coding.

**AVC :** Advanced Video Coding.

**BER :** Bit Error Rate

**BPSK:** Binary Phase Shift Keying

**CA :** Conditional Access

**CDM :** Code Division Multiplexing

**C/I :** Carrier to Interference

**DMB :** Digital Multimedia Broadcasting

**EN :** European Standard

**ES :** Elementary Stream

**ETSI:** European Telecommunications Standards Institute

**MPEG:** Moving Picture Experts Group

**PN :** Pseudo-random Noise

**PS :** Pilot Symbol

**QPSK:** Quadrature Phase Shift Keying

**RS :** Reed-Solomon

**SI :** Service Information

**TDM :** Time Division Multiplexing

**TS :** Transport Stream

---

## 9. Safety Precautions

---

### 9-1. Repair Precaution

- Repair in Shield Box, during detailed tuning.  
Take specially care of tuning or test,  
because specipcty of cellular phone is sensitive for surrounding interference(RF noise).
- Be careful to use a kind of magnetic object or tool,  
because performance of parts is damaged by the influence of manetic force.
- Surely use a standard screwdriver when you disassemble this product,  
otherwise screw will be worn away.
- Use a thicken twisted wire when you measure level.  
A thicken twisted wire has low resistance, therefore error of measurement is few.
- Repair after separate Test Pack and Set because for short danger (for example an  
overcurrent and furious flames of parts etc) when you repair board in condition of  
connecting Test Pack and tuning on.
- Take specially care of soldering, because Land of PCB is small and weak in heat.
- Surely tune on/off while using AC power plug, because a repair of battery charger is  
dangerous when tuning ON/OFF PBA and Connector after disassembling charger.
- Don't use as you pleases after change other material than replacement registered on SEC  
System. Otherwise engineer in charge isn't charged with problem that you don't keep this  
rules.

## 9-2. ESD(Electrostatically Sensitive Devices) Precaution

Several semiconductor may be damaged easily by static electricity. Such parts are called by ESD(Electrostatically Sensitive Devices), for example IC,BGA chip etc. Read Precaution below. You can prevent from ESD damage by static electricity.

- Remove static electricity remained your body before you touch semiconductor or parts with semiconductor. There are ways that you touch an earthed place or wear static electricity prevention string on wrist.
- Use earthed soldering steel when you connect or disconnect ESD.
- Use soldering removing tool to break static electricity. , otherwise ESD will be damaged by static electricity.
- Don't unpack until you set up ESD on product. Because most of ESD are packed by box and aluminum plate to have conductive power,they are prevented from static electricity.
- You must maintain electric contact between ESD and place due to be set up until ESD is connected completely to the proper place or a circuit board.



---

## 10. Product Function

---

### Main Function

- Speed dial
- Phonebook memory status
- SDN(Service Dialling Numbers)
- Network services
- Read SMS or MMS messages
- Send SMS or MMS messages
- Voicemail
- Broadcast message
- MMS profile
- SOS messages
- Web browser
- FM radio
- Menu shortcuts